

Laurent Series and z-Transform

- Geometric Series

Double Pole Examples (B)

20220720 Wed

Copyright (c) 2022 - 2016 Young W. Lim.

Permission is granted to copy, distribute and/or modify this document under the terms of the GNU Free Documentation License, Version 1.2 or any later version published by the Free Software Foundation; with no Invariant Sections, no Front-Cover Texts, and no Back-Cover Texts. A copy of the license is included in the section entitled "GNU Free Documentation License".

Reciprocal Pole Relation (p=3)

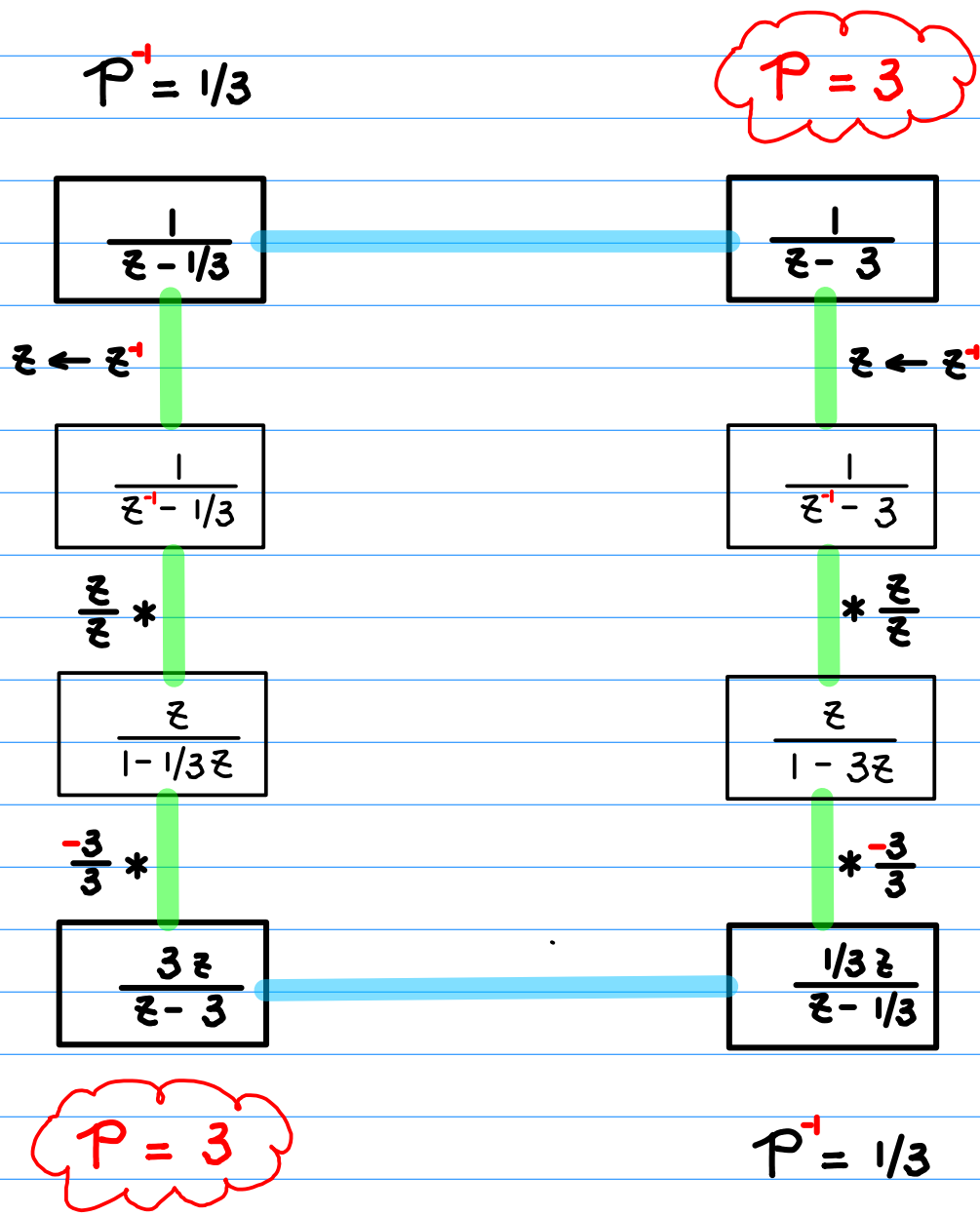

Reciprocal Pole Partial Fractions (p=3)

$$P^{-1} = 1/3$$

$$P = 3$$

$$\frac{3}{8} \frac{-1}{(z-1/3)(z-3)} = \left(\frac{1}{z-1/3} - \frac{1}{z-3} \right)$$

$$z \leftarrow z^{-1}$$

$$\frac{3}{8} \frac{-1}{(z^{-1}-1/3)(z^{-1}-3)} = \left(\frac{1}{z^{-1}-1/3} - \frac{1}{z^{-1}-3} \right)$$

$$* \frac{z}{z}$$

$-1, z^{-1}$

$$\frac{3}{8} \frac{-z^2}{(1-1/3z)(1-3z)} = \left(\frac{z}{(1-1/3z)} - \frac{z}{(1-3z)} \right)$$

$$* \frac{3}{3}$$

$$\frac{3}{8} \frac{-z^2 \cdot 3 \cdot 1/3}{(3-z)(1/3-z)} = \left(\frac{3z}{(3-z)} - \frac{1/3z}{(1/3-z)} \right)$$

$$* -1$$

$$\frac{3}{8} \frac{-z^2}{(z-1/3)(z-3)} = \left(\frac{1/3z}{z-1/3} - \frac{3z}{z-3} \right)$$

Reciprocal Pole Relation:
 Partial Fractions and
 Geometric Power Series

$$P^{-1} = 1/3$$

$$P = 3$$

$$\frac{3}{8} \frac{-1}{(z-1/3)(z-3)} = \left(\frac{1}{z-1/3} - \frac{1}{z-3} \right)$$

$-1, z^{-1}$

$$\frac{3}{8} \frac{-z^2}{(z-1/3)(z-3)} = \left(\frac{1/3 z}{z-1/3} - \frac{3z}{z-3} \right)$$

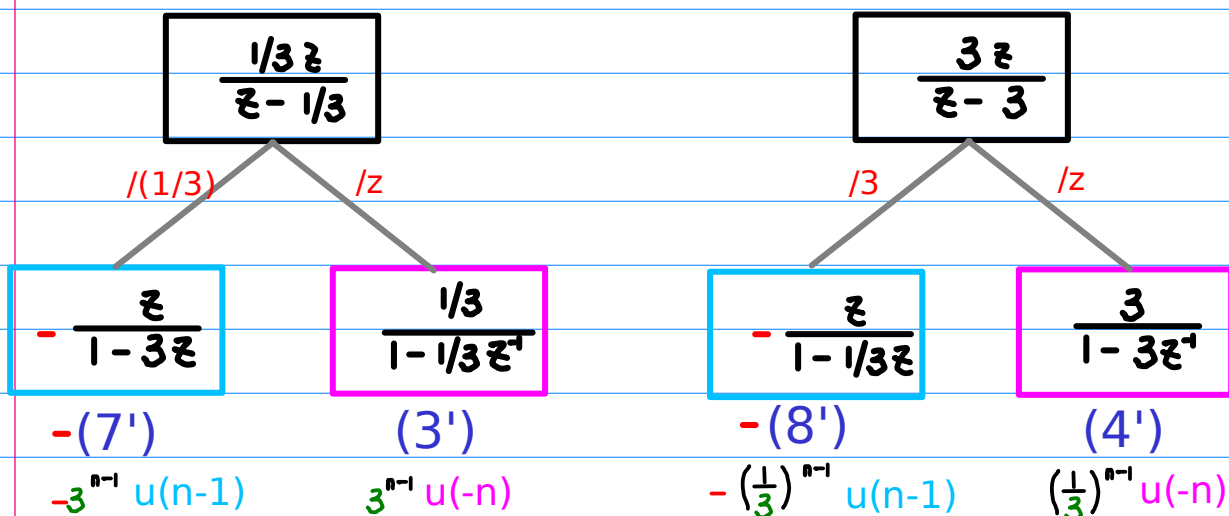
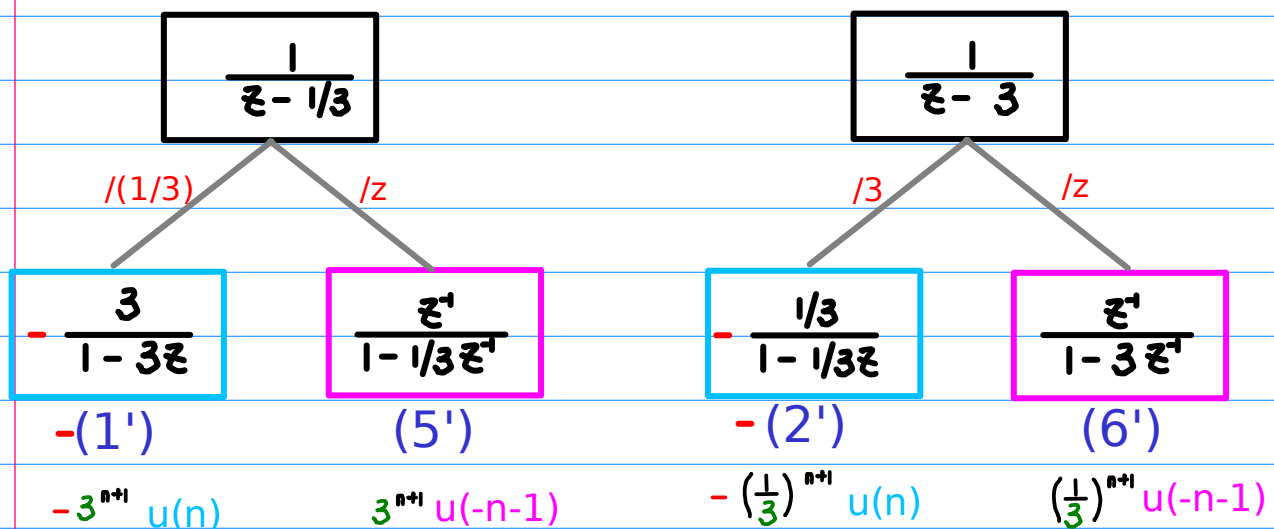

Reciprocal poles in Simple Pole Forms ($p=3$)

$$P^+ = 1/3$$

$$P^- = 3$$

$$P^+ = 1/3$$

$$\frac{1}{z - 1/3}$$

$$\frac{1}{z^+ - 1/3}$$

$$\frac{z}{1 - 1/3z}$$

$$-\frac{3z}{z - 3}$$

$$P^- = 3$$

$$\frac{1}{z - 3}$$

$$\frac{1}{z^+ - 3}$$

$$\frac{z}{1 - 3z}$$

$$-\frac{1/3z}{z - 1/3}$$

$$\frac{3}{8} \frac{-1}{(z - 1/3)(z - 3)} = \left(\frac{1}{z - 1/3} - \frac{1}{z - 3} \right)$$

$$\frac{1}{z - 1/3}$$

$$\frac{1}{z - 3}$$

$-1, z^+$

$-1, z^+$

$$\frac{1/3z}{z - 1/3}$$

$$\frac{3z}{z - 3}$$

$-1, z^+$

$$\frac{3}{8} \frac{-z^2}{(z - 1/3)(z - 3)} = \left(\frac{1/3z}{z - 1/3} - \frac{3z}{z - 3} \right)$$

Reciprocal poles in Geometric Series Forms (p=2)

Causal

$$\mathcal{P}^{-1} = 1/3$$

$$\mathcal{P} = 3$$

$$\mathcal{P}^{-1} = 1/3$$

$$\mathcal{P} = 3$$

$$-\frac{3}{1-3z}$$

$$-\frac{1/3}{1-1/3z}$$

$$-\frac{3}{1-3z^{-1}}$$

$$-\frac{1/3}{1-1/3z^{-1}}$$

$$-\frac{3z}{z-3}$$

$$\frac{z}{1-3z}$$

$$\frac{z}{1-1/3z}$$

$$\frac{z}{1-3z}$$

$$\frac{3}{8} \frac{-1}{(z-1/3)(z-3)} = \left(\frac{1}{z-1/3} - \frac{1}{z-3} \right)$$

$$-(1') \quad -3^{n+1} u(n) \quad -\frac{3}{1-3z} \quad -\left(\frac{1}{3}\right)^{n+1} u(n) \quad -\frac{1/3}{1-1/3z} \quad (2')$$

$$-(7') \quad -\frac{z}{1-3z} \quad -3^{n-1} u(n-1) \quad -\frac{z}{1-1/3z} \quad -\left(\frac{1}{3}\right)^{n-1} u(n-1) \quad (8')$$

$-1, z^{-1}$

$$\frac{3}{8} \frac{-z^2}{(z-1/3)(z-3)} = \left(\frac{1/3z}{z-1/3} - \frac{3z}{z-3} \right)$$

Reciprocal poles in Geometric Series Forms (p=2)

Anti-causal

$$\mathcal{P}^{-1} = 1/3$$

$$\mathcal{P} = 3$$

$$\mathcal{P}^{-1} = 1/3$$

$$\mathcal{P} = 3$$

$$\frac{z^{-1}}{1 - 1/3 z^{-1}}$$

$$\frac{z^{-1}}{1 - 3z^{-1}}$$

$$\frac{z^{-n}}{1 - 1/3 z^{-n}}$$

$$\frac{z^{-n}}{1 - 3z^{-n}}$$

$$\frac{1}{z^{-1} - 1/3}$$

$$\frac{1}{z^{-1} - 3}$$

$$- \frac{3}{1 - 3z^{-1}}$$

$$- \frac{0.5}{1 - 0.5z^{-1}}$$

$$\frac{3}{8} \frac{-1}{(z - 1/3)(z - 3)} = \left(\frac{1}{z - 1/3} - \frac{1}{z - 3} \right)$$

$$3^{n+1} u(-n-1)$$

$$\left(\frac{1}{3}\right)^{n+1} u(-n-1)$$

$$(5') \frac{z^{-1}}{1 - 1/3 z^{-1}}$$

$$(6') \frac{z^{-1}}{1 - 3z^{-1}}$$

$-1, z^{-1}$

$-1, z^{-1}$

$-1, z^{-1}$

$$(3') \frac{0.5}{1 - 0.5z^{-1}}$$

$$\frac{3}{1 - 3z^{-1}} (4')$$

$$3^{n-1} u(-n)$$

$$\left(\frac{1}{3}\right)^{n-1} u(-n)$$

$$\frac{3}{8} \frac{-z^2}{(z - 1/3)(z - 3)} = \left(\frac{1/3 z}{z - 1/3} - \frac{3z}{z - 3} \right)$$

Reciprocal Pole Relation :
 Shifted version and
 Unshifted version

$$P^{-1} = 1/3$$

$$P = 3$$

$$\frac{1}{z - 1/3} \quad \frac{1}{z - 3}$$

$-1, z^{-1}$ $-1, z^{-1}$

$$\frac{1/3z}{z - 1/3} \quad \frac{3z}{z - 3}$$

$$\frac{3}{2} \frac{-1}{(z - 0.5)(z - 2)}$$

$-1, z^{-1}$

$$-\frac{3}{2} \frac{z^2}{(z - 0.5)(z - 2)}$$

$-(1')$ $-(2')$

$$-\frac{3}{1 - 3z} \quad -\frac{1/3}{1 - 1/3z}$$

$-1, z^{-1}$ $-1, z^{-1}$

$$-\frac{z}{1 - 3z} \quad -\frac{z}{1 - 1/3z}$$

$-(7')$ $-(8')$

$(5')$ $(6')$

$$\frac{z^{-1}}{1 - 1/3z^{-1}} \quad \frac{z^{-1}}{1 - 3z^{-1}}$$

$-1, z^{-1}$ $-1, z^{-1}$

$$\frac{1/3}{1 - 1/3z^{-1}} \quad \frac{3}{1 - 3z^{-1}}$$

$(3')$ $(4')$

$-(1)$ $-(2)$

$$-\frac{1}{1 - 3z} \quad -\frac{1}{1 - 1/3z}$$

$-1, z^{-1}$ $-1, z^{-1}$

$$-\frac{3z}{1 - 3z} \quad -\frac{1/3z}{1 - 1/3z}$$

$-(7)$ $-(8)$

(5) (6)

$$\frac{1/3z^{-1}}{1 - 1/3z^{-1}} \quad \frac{3z^{-1}}{1 - 3z^{-1}}$$

$-1, z^{-1}$ $-1, z^{-1}$

$$\frac{1}{1 - 1/3z^{-1}} \quad \frac{1}{1 - 3z^{-1}}$$

(3) (4)

Reciprocal Pole and Shift Relations

$$P^+ = 1/3$$

$$P = 3$$

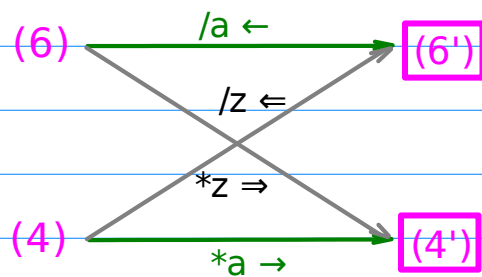
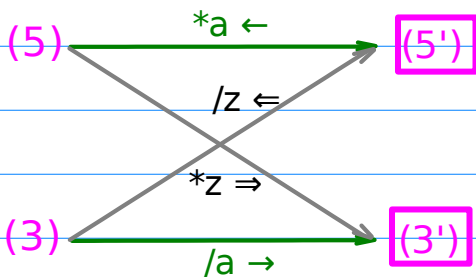
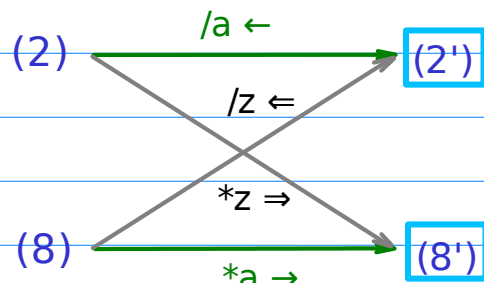
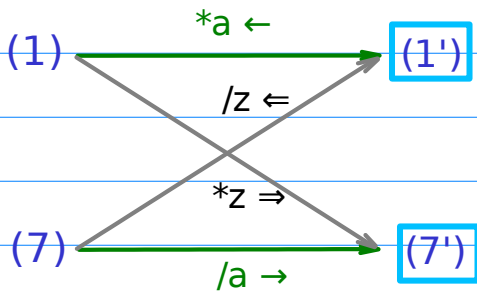
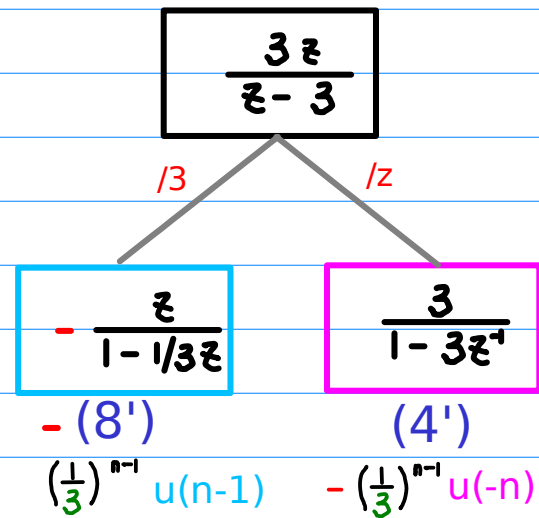
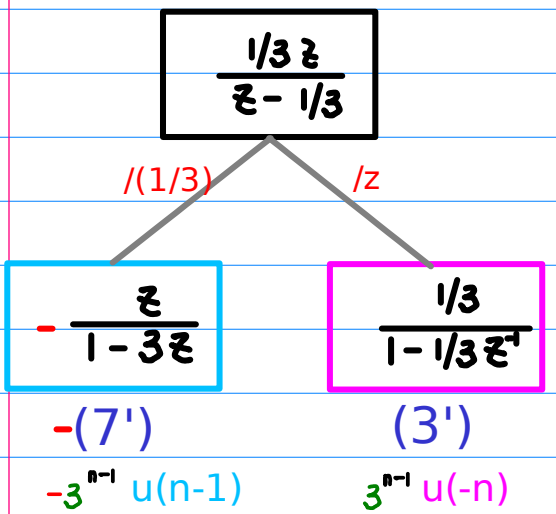
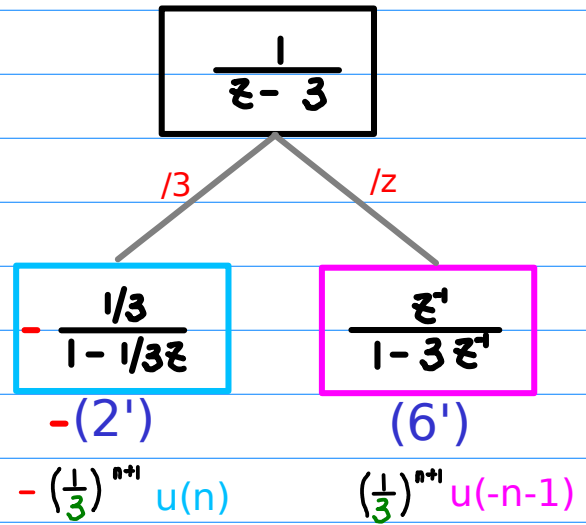
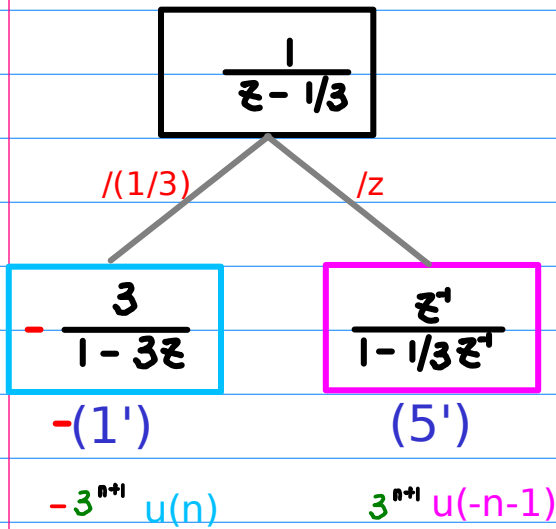

(1) (5) (2) (6)
(7) (3) (8) (4)

(1') (5') (2')(6')
(7') (3') (8')(4')

Partial fractions and geometric power series

$$\mathcal{P}^{-1} = 1/3$$

$$\mathcal{P} = 3$$

-(1)
$$-\frac{1}{1-3z}$$

$$-3^n u(n)$$

(5)
$$\frac{1/3 z^{-1}}{1-1/3 z^{-1}}$$

$$3^n u(-n-1)$$

-(2)
$$-\frac{1}{1-1/3 z}$$

$$-3^{-n} u(n)$$

(6)
$$\frac{3 z^{-1}}{1-3 z^{-1}}$$

$$3^{-n} u(-n-1)$$

-(7)
$$-\frac{3z}{1-3z}$$

$$-3^n u(n-1)$$

(3)
$$\frac{1}{1-1/3 z^{-1}}$$

$$3^n u(-n)$$

-(8)
$$-\frac{1/3 z}{1-1/3 z}$$

$$-3^{-n} u(n-1)$$

(4)
$$\frac{1}{1-3 z^{-1}}$$

$$3^{-n} u(-n)$$

-(1')
$$-\frac{3}{1-3z}$$

$$-3^{n+1} u(n)$$

(5')
$$\frac{z^{-1}}{1-1/3 z^{-1}}$$

$$3^{n+1} u(-n-1)$$

-(2')
$$-\frac{1/3}{1-1/3 z}$$

$$-3^{-n-1} u(n)$$

(6')
$$\frac{z^{-1}}{1-3 z^{-1}}$$

$$3^{-n-1} u(-n-1)$$

-(7')
$$-\frac{z}{1-3z}$$

$$-3^{n-1} u(n-1)$$

(3')
$$-\frac{1/3}{1-1/3 z^{-1}}$$

$$3^{n-1} u(-n)$$

-(8')
$$-\frac{z}{1-1/3 z}$$

$$-3^{-n-1} u(n-1)$$

(4')
$$\frac{3}{1-3 z^{-1}}$$

$$3^{-n-1} u(-n)$$

(Exp, Range)

$$P^{-1} = 1/3$$
$$P = 3$$

(1) $\frac{1}{1-3z}$ $\xrightarrow[*a \leftarrow]{/z \leftarrow}$ $\frac{3}{1-3z}$ (1')

$$\begin{array}{ccc} 3^n & \xrightarrow{(n \rightarrow n+1, id)} & 3^{n+1} \\ u(n) & & u(n) \end{array}$$

(7) $\frac{3z}{1-3z}$ $\xrightarrow[*z \Rightarrow]{/a \rightarrow}$ $\frac{z}{1-3z}$ (7')

$$\begin{array}{ccc} 3^n & \xrightarrow{(n \rightarrow n-1, id)} & 3^{n-1} \\ u(n-1) & & u(n-1) \end{array}$$

(5) $\frac{1/3z^{-1}}{1-1/3z^{-1}}$ $\xrightarrow[*a \leftarrow]{/z \leftarrow}$ $\frac{z^{-1}}{1-1/3z^{-1}}$ (5')

$$\begin{array}{ccc} 3^n & \xrightarrow{(n \rightarrow n+1, id)} & 3^{n+1} \\ u(-n-1) & & u(-n-1) \end{array}$$

(3) $\frac{1}{1-1/3z^{-1}}$ $\xrightarrow[*z \Rightarrow]{/a \rightarrow}$ $\frac{1/3}{1-1/3z^{-1}}$ (3')

$$\begin{array}{ccc} 3^n & \xrightarrow{(n \rightarrow n-1, id)} & 3^{n-1} \\ u(-n) & & u(-n) \end{array}$$

(2) $\frac{1}{1-1/3z}$ $\xrightarrow[*a \leftarrow]{/z \leftarrow}$ $\frac{1/3}{1-1/3z}$ (2')

$$\begin{array}{ccc} (\frac{1}{3})^n & \xrightarrow{(n \rightarrow n+1, id)} & (\frac{1}{3})^{n+1} \\ u(n) & & u(n) \end{array}$$

(8) $\frac{1/3z}{1-1/3z}$ $\xrightarrow[*z \Rightarrow]{*a \rightarrow}$ $\frac{z}{1-1/3z}$ (8')

$$\begin{array}{ccc} (\frac{1}{3})^n & \xrightarrow{(n \rightarrow n-1, id)} & (\frac{1}{3})^{n-1} \\ u(n-1) & & u(n-1) \end{array}$$

(6) $\frac{1/3z}{1-1/3z}$ $\xrightarrow[*z \Rightarrow]{/a \leftarrow}$ $\frac{z}{1-1/3z}$ (6')

$$\begin{array}{ccc} (\frac{1}{3})^n & \xrightarrow{(n \rightarrow n+1, id)} & (\frac{1}{3})^{n+1} \\ u(-n-1) & & u(-n-1) \end{array}$$

(4) $\frac{1}{1-3z^{-1}}$ $\xrightarrow[*z \Rightarrow]{/ *}$ $\frac{3}{1-3z^{-1}}$ (4')

$$\begin{array}{ccc} (\frac{1}{3})^n & \xrightarrow{(n \rightarrow n-1, id)} & (\frac{1}{3})^{n-1} \\ u(-n) & & u(-n) \end{array}$$

$$P^{-1} = 1/3$$

$$P = 3$$

(1) $\frac{1}{1-3z}$ $\xrightarrow[*a \leftarrow]{/z \leftarrow}$ $-\frac{3}{1-3z}$ (1')

$\frac{3^n}{u(n)}$ $\xrightarrow[(n \rightarrow n+1, n \rightarrow n+1)]{}$ $-\frac{3^{n+1}}{u(n)}$

(7) $\frac{3z}{1-3z}$ $\xrightarrow[*z \Rightarrow]{/a \rightarrow}$ $\frac{z}{1-3z}$ (7')

$\frac{3^n}{u(n-1)}$ $\xrightarrow[(n \rightarrow n-1, n \rightarrow n-1)]{}$ $-\frac{3^{n-1}}{u(n-1)}$

(5) $\frac{1/3z^{-1}}{1-1/3z^{-1}}$ $\xrightarrow[*a \leftarrow]{/z \leftarrow}$ $\frac{z^{-1}}{1-1/3z^{-1}}$ (5')

$\frac{3^n}{u(-n-1)}$ $\xrightarrow[(n \rightarrow n+1, n \rightarrow n+1)]{}$ $\frac{3^{n+1}}{u(-n-1)}$

(3) $\frac{1}{1-1/3z^{-1}}$ $\xrightarrow[*z \Rightarrow]{/a \rightarrow}$ $-\frac{1/3}{1-1/3z^{-1}}$ (3')

$\frac{3^n}{u(-n)}$ $\xrightarrow[(n \rightarrow n-1, n \rightarrow n-1)]{}$ $\frac{3^{n-1}}{u(-n-1)}$

(2) $\frac{1}{1-1/3z}$ $\xrightarrow[*a \leftarrow]{/z \leftarrow}$ $-\frac{1/3}{1-1/3z}$ (2')

$\frac{(\frac{1}{3})^n}{u(n)}$ $\xrightarrow[(n \rightarrow n+1, n \rightarrow n+1)]{}$ $-\frac{(\frac{1}{3})^{n+1}}{u(n)}$

(8) $\frac{1/3z}{1-1/3z}$ $\xrightarrow[*z \Rightarrow]{*a \rightarrow}$ $\frac{z}{1-1/3z}$ (8')

$\frac{(\frac{1}{3})^n}{u(n-1)}$ $\xrightarrow[(n \rightarrow n-1, n \rightarrow n-1)]{}$ $-\frac{(\frac{1}{3})^{n-1}}{u(n-1)}$

(6) $\frac{1/3z}{1-1/3z}$ $\xrightarrow[*a \leftarrow]{/z \leftarrow}$ $\frac{z}{1-1/3z}$ (6')

$\frac{(\frac{1}{3})^n}{u(-n-1)}$ $\xrightarrow[(n \rightarrow n+1, n \rightarrow n+1)]{}$ $\frac{(\frac{1}{3})^{n+1}}{u(-n-1)}$

(4) $\frac{1}{1-3z^{-1}}$ $\xrightarrow[*z \Rightarrow]{/3^*}$ $-\frac{3}{1-3z^{-1}}$ (4')

$\frac{(\frac{1}{3})^n}{u(-n)}$ $\xrightarrow[(n \rightarrow n-1, n \rightarrow n-1)]{}$ $\frac{(\frac{1}{3})^{n-1}}{u(-n)}$



Partial Fraction Decompositions

$$P_1 = 1$$

$$P_2 = 2$$

$$\begin{aligned} - \frac{1}{(z-1)(z-2)} &= \left(\frac{1}{z-1} - \frac{1}{z-2} \right) \\ &= \frac{(z-2) - (z-1)}{(z-1)(z-2)} \\ &= \frac{-1}{(z-1)(z-2)} \end{aligned}$$

$$\begin{aligned} - \frac{z^2}{(z-1)(z-2)} &= \left(\frac{z}{z-1} - \frac{2z}{z-2} \right) \\ &= \frac{z^2 - 2z - 2z^2 + 2z}{(z-1)(z-2)} \\ &= \frac{-z^2}{(z-1)(z-2)} \end{aligned}$$

$$\begin{aligned} - \frac{z}{(z-0.5)(z-2)} &= \left(\frac{1}{z-1} - \frac{4}{z-2} \right) \\ &= \frac{(z-2) - 4(z-1)}{(z-1)(z-2)} \\ &= \frac{-z}{(z-1)(z-2)} \end{aligned}$$

Partial fractions as geometric power series

$$\frac{1}{(z-1)(z-2)} = \left(\frac{1}{z-1} - \frac{1}{z-2} \right)$$

$$\begin{aligned} P_1 &= 1 \\ P_2 &= 2 \end{aligned}$$

Simple Pole Form

$$\frac{1}{z-1}$$

/1

/z

$$\frac{1}{1-z}$$

$$\frac{z^{-1}}{1-z^{-1}}$$

Geometric Power Series Forms

Simple Pole Form

$$\frac{1}{z-2}$$

/2

/z

$$\frac{0.5}{1-0.5z}$$

$$\frac{z^{-1}}{1-2z^{-1}}$$

Geometric Power Series Forms

$$\frac{z^2}{(z-1)(z-2)} = \left(\frac{z}{z-1} - \frac{2z}{z-2} \right)$$

$$\begin{aligned} P_1 &= 1 \\ P_2 &= 2 \end{aligned}$$

Simple Pole Form

$$\frac{z}{z-1}$$

/1

/z

$$\frac{z}{1-z}$$

$$\frac{1}{1-z^{-1}}$$

Geometric Power Series Forms

Simple Pole Form

$$\frac{2z}{z-2}$$

/2

/z

$$\frac{z}{1-0.5z}$$

$$\frac{2}{1-2z^{-1}}$$

Geometric Power Series Forms

ROC Cases for irreducible polynomials

$(z-1), (z-2)$

$$\frac{\square}{(z-1)(z-2)}$$

(A)

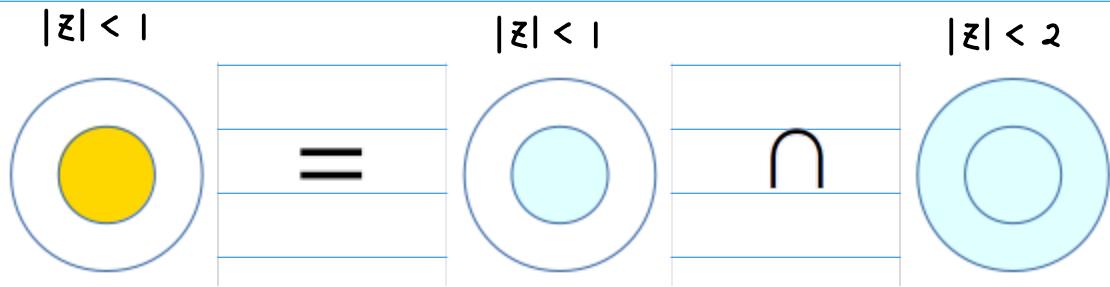

(B)

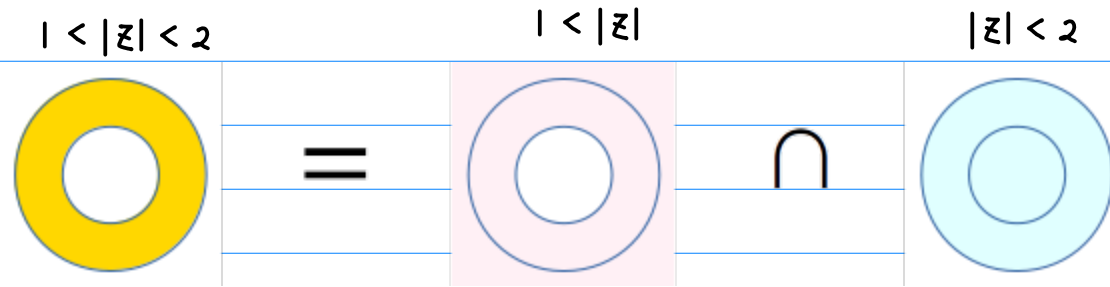

(C)

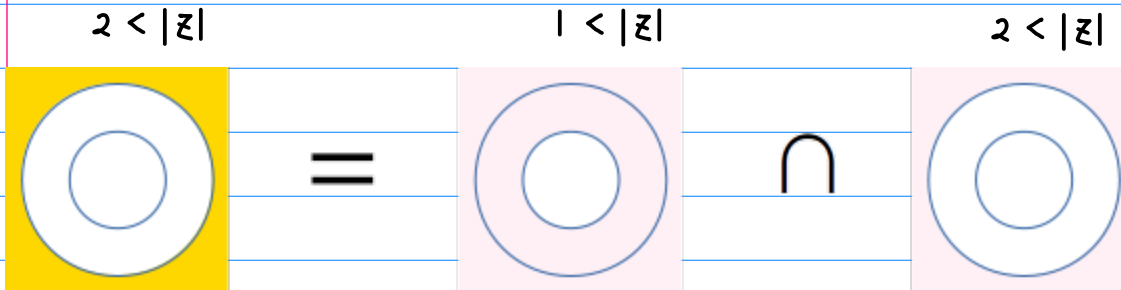

Finding a common ratio

$$P_1 = 1$$
$$P_2 = 2$$

$$\frac{1}{(z-1)(z-2)}$$

$$\frac{z^2}{(z-1)(z-2)}$$

$$\frac{z}{(z-0.5)(z-2)}$$

Irreducible Polynomials

$$(z-1)$$

$$(z-2)$$

Geometric Power Series From

$$\frac{1}{(z-1)}$$

$$\frac{1}{(z-2)}$$



$$-\frac{1}{1-z}$$

$$-\frac{z^1}{1-2^1 z}$$



$$(1) \quad 1z$$

$$2^{-1}z \quad (2)$$

$$1^n u(n)$$

$$2^{-n} u(n)$$

Finding a geometric series

$$P_1 = 1$$

$$P_2 = 2$$

Irreducible Polynomials

$$(z-1) \quad (z-2)$$

Geometric Power Series From

$$\frac{1}{(z-1)} \quad \frac{1}{(z-2)}$$

$$-\frac{1}{1-z} \quad -\frac{2^i}{1-2^i z}$$

$$\Downarrow \quad \Downarrow$$

$$1 \cdot \frac{1}{1-z} \quad 2^i \cdot \frac{1}{1-2^i z}$$

$$a=1$$

$$a^i=2^i$$

	$1^n u(n)$		$2^n u(n)$	
(1)	az	$+\frac{1}{1-az}$	$+\frac{1}{1-a^i z}$	(2)
(3)	$a^{-1}z^{-1}$	$-\frac{1}{1-a^{-1}z^{-1}}$	$-\frac{1}{1-a^i z^{-1}}$	(4)
(5)	$a^{-1}z^{-1}$	$-\frac{a^{-1}z^{-1}}{1-a^{-1}z^{-1}}$	$-\frac{a^i z^{-1}}{1-a^i z^{-1}}$	(6)
(7)	az	$+\frac{az}{1-az}$	$+\frac{a^i z}{1-a^i z}$	(8)

$$\begin{matrix} (1) (1') & (2) (2') \\ (7) (7') & (8) (8') \end{matrix}$$

$$\begin{matrix} (5) (5') & (6) (6') \\ (3) (3') & (4) (4') \end{matrix}$$

$$\begin{matrix} P_1 = 1 \\ P_2 = 2 \end{matrix}$$

Irreducible Polynomials

Geometric Power Series From

$$\frac{1}{(z-1)}$$

$$\frac{1}{(z-2)}$$

$$\begin{matrix} \rightarrow -\frac{1}{1-|z|} & \rightarrow -\frac{z'}{1-2z'} \\ \Downarrow & \Downarrow \\ \rightarrow 1 \cdot \frac{1}{1-|z|} & \rightarrow 2' \cdot \frac{1}{1-2z'} \end{matrix}$$

$$a=1$$

$$a'=2'$$

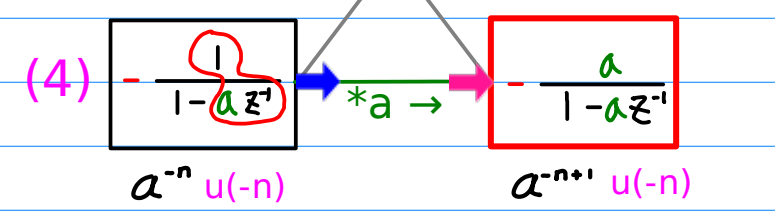
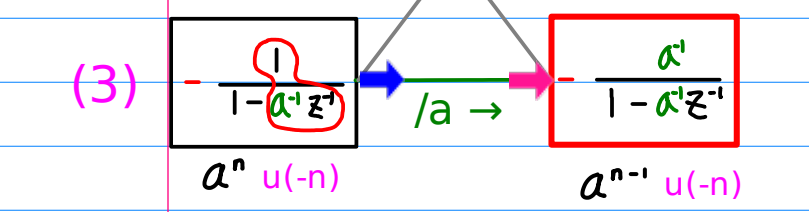
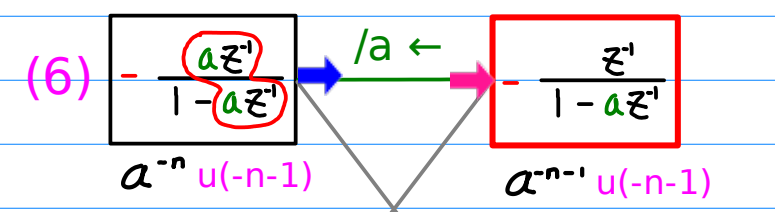
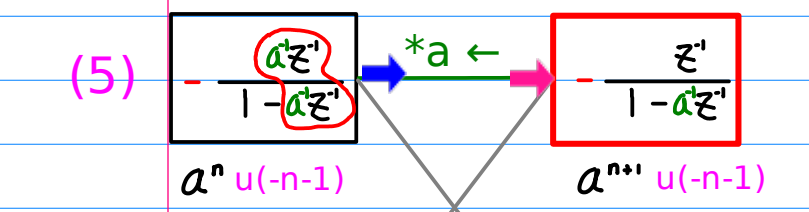
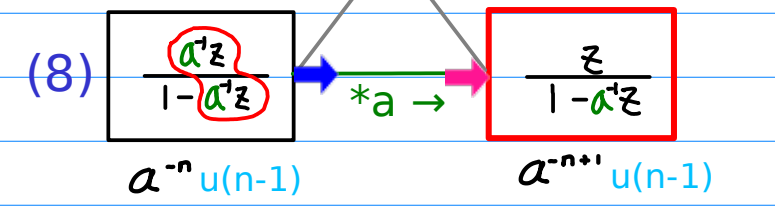
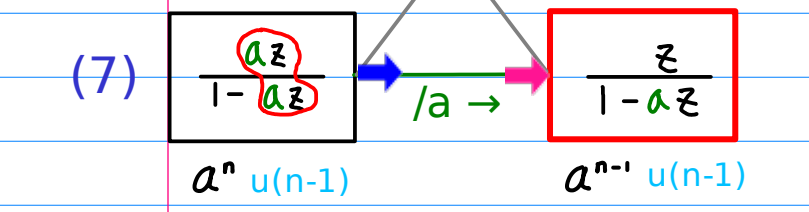
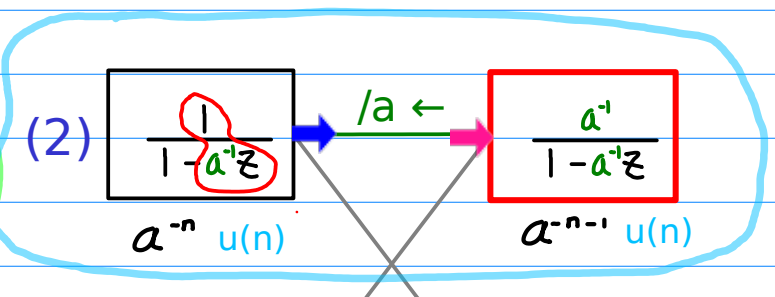
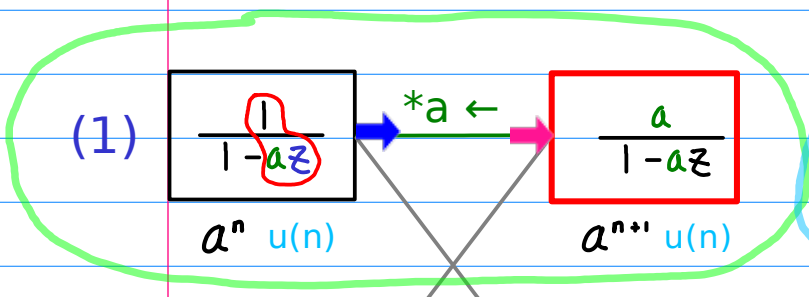

$$a=1$$

- (1) (2)
- (3) (4)
- (5) (6)
- (7) (8)

<p>(1) $^n u(n)$ $\xrightarrow{*1 \leftarrow}$ $^{n+1} u(n)$ z z^{-1}</p> <p>(3) $^n u(-n)$ $\xrightarrow{/1 \rightarrow}$ $^{n-1} u(-n)$ z^{-1} z</p> <p>(5) $^n u(-n-1)$ $\xrightarrow{*1 \leftarrow}$ $^{n+1} u(-n-1)$ z^{-1} z^{-1}</p> <p>(7) $^n u(n-1)$ $\xrightarrow{/1 \rightarrow}$ $^{n-1} u(n-1)$ z z^{-1}</p>	<p>(2) $^{-n} u(n)$ $\xrightarrow{/1 \leftarrow}$ $^{-n-1} u(n)$ z^{-1} z^{-1}</p> <p>(4) $^{-n} u(-n)$ $\xrightarrow{*1 \rightarrow}$ $^{-n+1} u(-n)$ z z^{-1}</p> <p>(6) $^{-n} u(-n-1)$ $\xrightarrow{/1 \leftarrow}$ $^{-n-1} u(-n-1)$ z^{-1} z^{-1}</p> <p>(8) $^{-n} u(n-1)$ $\xrightarrow{*1 \rightarrow}$ $^{-n+1} u(n-1)$ z^{-1} z</p>
--	---

$$a=2$$

- (1) (2)
- (3) (4)
- (5) (6)
- (7) (8)

(1) $2^n u(n) \rightarrow 2^{n+1} u(n)$

$$\frac{1}{1-2z} \xrightarrow{*2 \leftarrow} \frac{2}{1-2z}$$

$$2z$$

$$2^{-1}z$$

(2) $2^{-n} u(n) \rightarrow 2^{-n-1} u(n)$

$$\frac{1}{1-2^{-1}z} \xrightarrow{/2 \leftarrow} \frac{2^{-1}}{1-2^{-1}z}$$

(3) $2^n u(-n) \rightarrow 2^{n-1} u(-n)$

$$\frac{1}{1-2^{-1}z^{-1}} \xrightarrow{/2 \rightarrow} \frac{2^{-1}}{1-2^{-1}z^{-1}}$$

$$2^{-1}z^{-1}$$

$$2z^{-1}$$

(4) $2^{-n} u(-n) \rightarrow 2^{-n+1} u(-n)$

$$\frac{1}{1-2z^{-1}} \xrightarrow{*2 \rightarrow} \frac{2}{1-2z^{-1}}$$

(5) $2^n u(n-1) \rightarrow 2^{n+1} u(n-1)$

$$\frac{2^{-1}z^{-1}}{1-2^{-1}z^{-1}} \xrightarrow{*2 \leftarrow} \frac{z^{-1}}{1-2^{-1}z^{-1}}$$

$$2^{-1}z^{-1}$$

$$2z^{-1}$$

(6) $2^{-n} u(n-1) \rightarrow 2^{-n-1} u(n-1)$

$$\frac{2z^{-1}}{1-2z^{-1}} \xrightarrow{/2 \leftarrow} \frac{z^{-1}}{1-2z^{-1}}$$

(7) $2^n u(n-1) \rightarrow 2^{n-1} u(n-1)$

$$\frac{2z}{1-2z} \xrightarrow{/2 \rightarrow} \frac{z}{1-2z}$$

$$2z$$

$$2^{-1}z$$

(8) $2^{-n} u(n-1) \rightarrow 2^{-n+1} u(n-1)$

$$\frac{2^{-1}z}{1-2^{-1}z} \xrightarrow{*2 \rightarrow} \frac{z}{1-2^{-1}z}$$

$$-\frac{1}{(z-1)(z-2)} = \left(\frac{1}{z-1} - \frac{1}{z-2} \right)$$

$$P_1 = 1$$

$$P_2 = 2$$

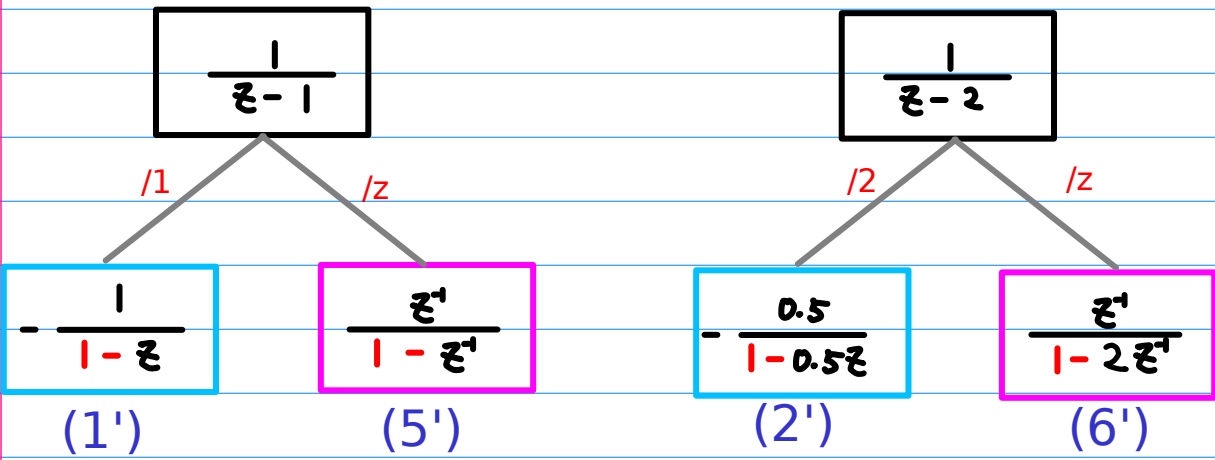

Complementary Ranges

Complementary Ranges

Case A	$ z < 1$	(1')	(2')
Case B	$1 < z < 2$	(5')	(2')
Case C	$2 < z $	(5')	(6')

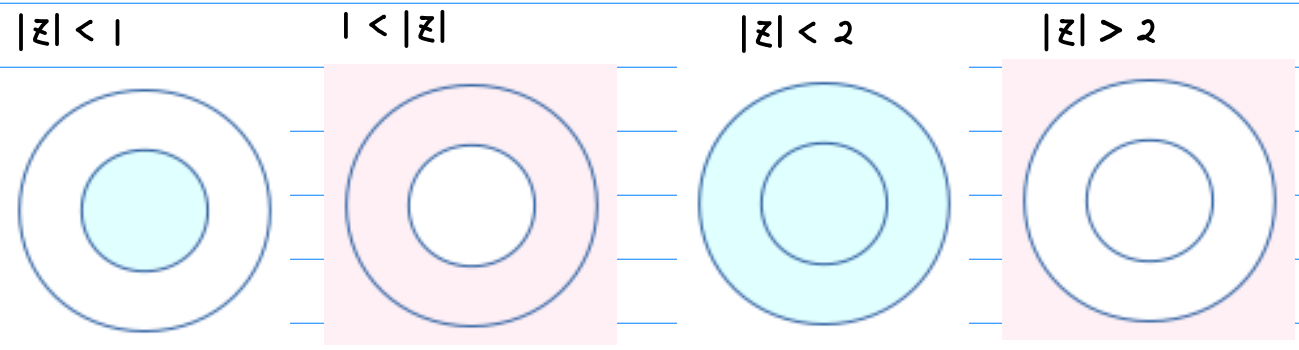

$-\left(\frac{1}{1}\right)^{n+1} u(n)$	$\left(\frac{1}{1}\right)^{n+1} u(-n-1)$	$-\left(\frac{1}{2}\right)^{n+1} u(n)$	$\left(\frac{1}{2}\right)^{n+1} u(-n-1)$
--	--	--	--

$-\frac{1}{1-z}$	$\frac{z^1}{1-z^1}$	$-0.5 \cdot \frac{1}{1-0.5z}$	$0.5 \cdot \frac{2z^1}{1-2z^1}$
------------------	---------------------	-------------------------------	---------------------------------

$$-\frac{z^2}{(z-1)(z-2)} = \left(\frac{z}{z-1} - \frac{2z}{z-2} \right)$$

$$P_1 = 1$$

$$P_2 = 2$$

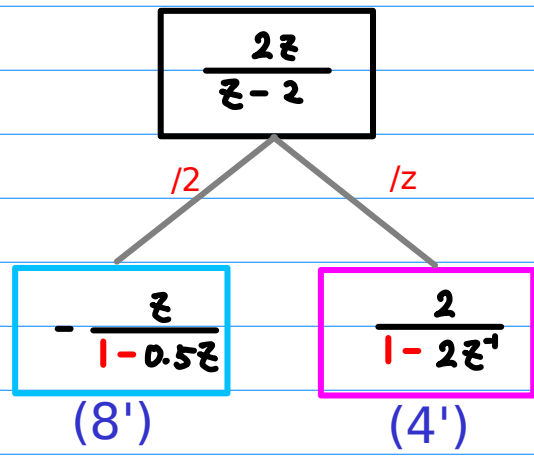
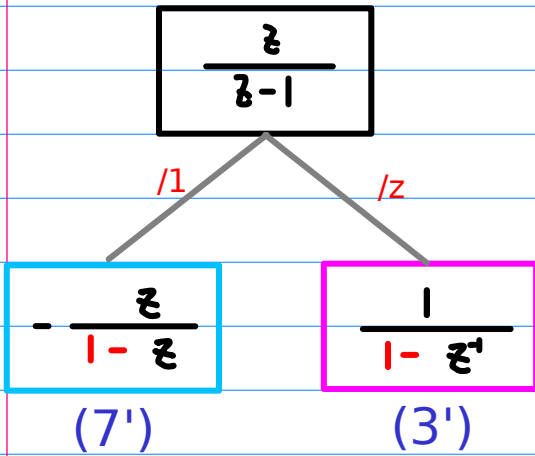

Complementary Ranges

Complementary Ranges

Case A $|z| < 1$

(7') (8')

Case B $1 < |z| < 2$

(3') (8')

Case C $2 < |z|$

(3') (4')

$|z| < 1$

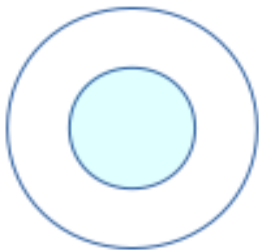

$$-\left(\frac{1}{1}\right)^{n+1} u(n)$$

$$-1 \cdot \frac{1}{1-z}$$

$1 < |z|$

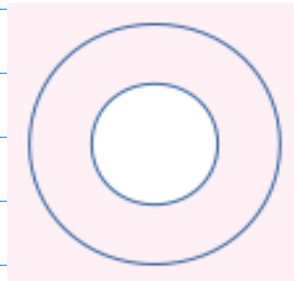

$$\left(\frac{1}{1}\right)^{n+1} u(-n-1)$$

$$1 \cdot \frac{1}{1-z^{-1}}$$

$|z| < 2$

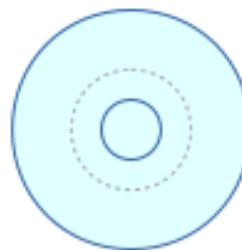

$$-\left(\frac{1}{2}\right)^{n-1} u(n-1)$$

$$-2 \cdot \frac{0.5z}{1-0.5z}$$

$|z| > 2$



$$\left(\frac{1}{2}\right)^{n-1} u(-n)$$

$$2 \cdot \frac{1}{1-2z^{-1}}$$

Partial fractions and geometric power series

$$\mathcal{P}_1 = 1$$

$$\mathcal{P}_2 = 2$$

$$\frac{1}{(z-1)(z-2)} = \left(\frac{1}{z-1} - \frac{1}{z-2} \right)$$

$$\frac{z^2}{(z-1)(z-2)} = \left(\frac{z}{z-1} - \frac{2z}{z-2} \right)$$

$$\mathcal{P}_1 = 1$$

$$\mathcal{P}_2 = 2$$

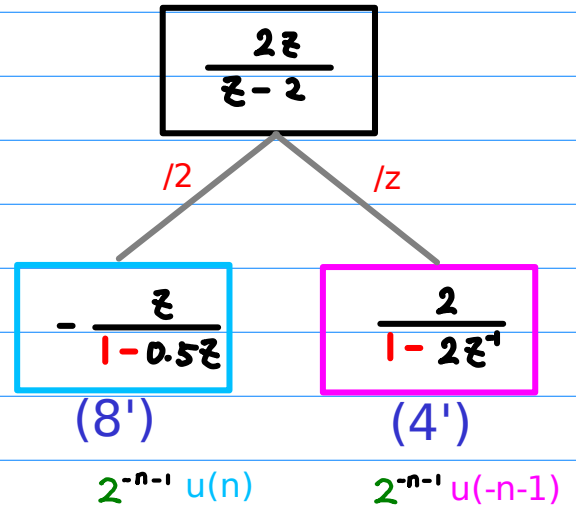
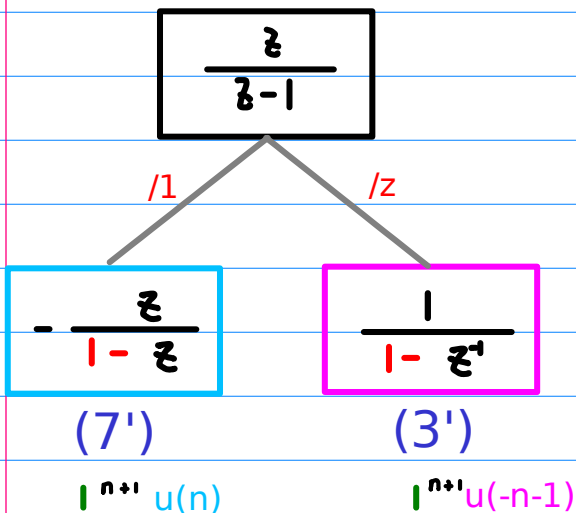
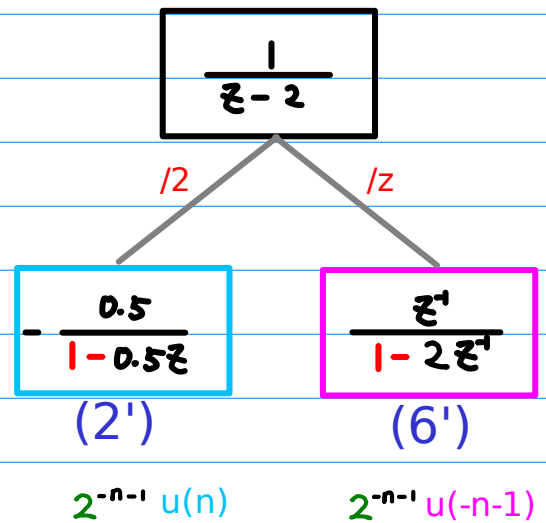
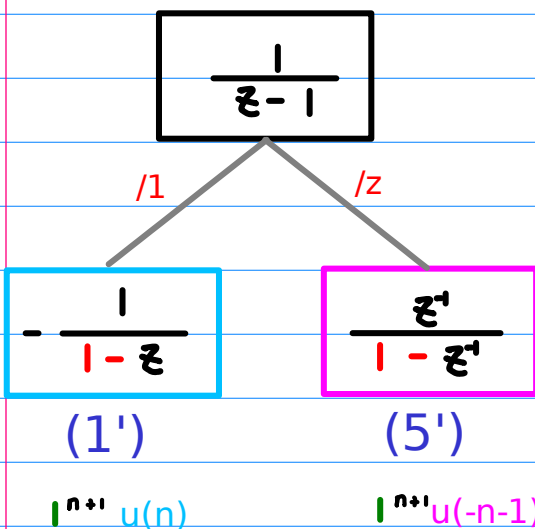

Reciprocal Pole Relation ($p_1=1, p_2=2$)

$$\frac{-1}{(z-1)(z-2)} = \left(\frac{1}{z-1} - \frac{1}{z-2} \right)$$

$$\frac{-1}{(z^{-1}-1)(z^{-1}-2)} = \left(\frac{1}{z^{-1}-1} - \frac{1}{z^{-1}-2} \right)$$

$$\frac{-z^2}{(1-1 \cdot z)(1-2z)} = \left(\frac{z}{(1-1 \cdot z)} - \frac{z}{(1-2z)} \right)$$

$$\frac{-z^2 \cdot 1 \cdot 0.5}{(1-z)(0.5-z)} = \left(\frac{z}{(1-z)} - \frac{0.5z}{(0.5-z)} \right)$$

$$\frac{1}{2} \frac{-z^2}{(z-1)(z-0.5)} = \left(-\frac{z}{z-1} + \frac{0.5z}{z-0.5} \right)$$

z^{-1}

$$z-1 \quad -z+1$$

$$\frac{1}{2} \frac{-1}{(z-1)(z-1)} = \left(\frac{1}{z-1} - \frac{1}{z-1} \right)$$

$$\frac{1}{2} \frac{-1}{(z^{-1}-1)(z^{-1}-1)} = \left(\frac{1}{z^{-1}-1} - \frac{1}{z^{-1}-1} \right)$$

z^{-1}

$$\frac{1}{2} \frac{-z^2}{(1-1 \cdot z)(1-2z)} = \left(\frac{z}{(1-1 \cdot z)} - \frac{z}{(1-2z)} \right)$$

$$\frac{1}{2} \frac{-z^2 \cdot 1 \cdot 0.5}{(1-z)(0.5-z)} = \left(\frac{z}{(1-z)} - \frac{0.5z}{(0.5-z)} \right)$$

$$\frac{1}{2} \frac{-z^2}{(z-1)(z-0.5)} = \left(-\frac{z}{z-1} + \frac{0.5z}{z-0.5} \right)$$

(Exp, Range)

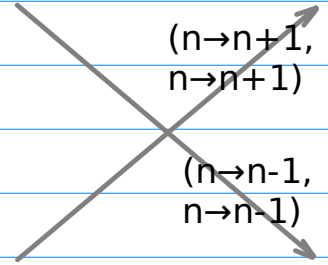
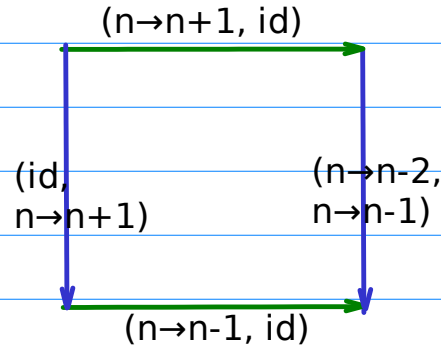
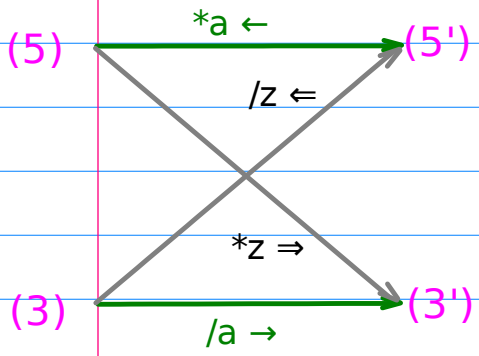
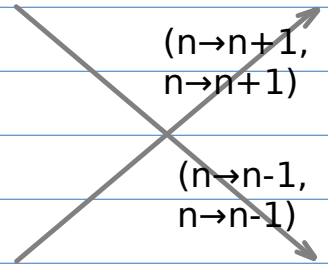
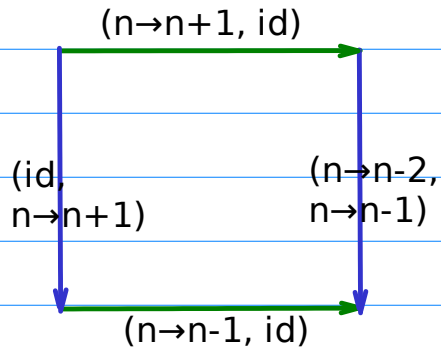
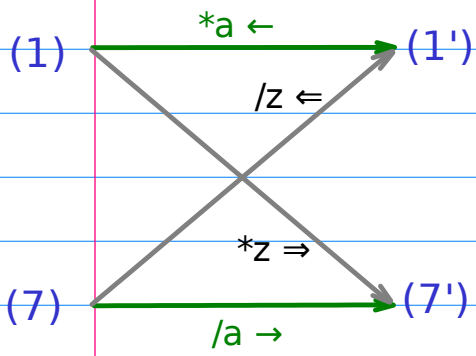

$$P_1 = 1$$

$$P_2 = 1$$

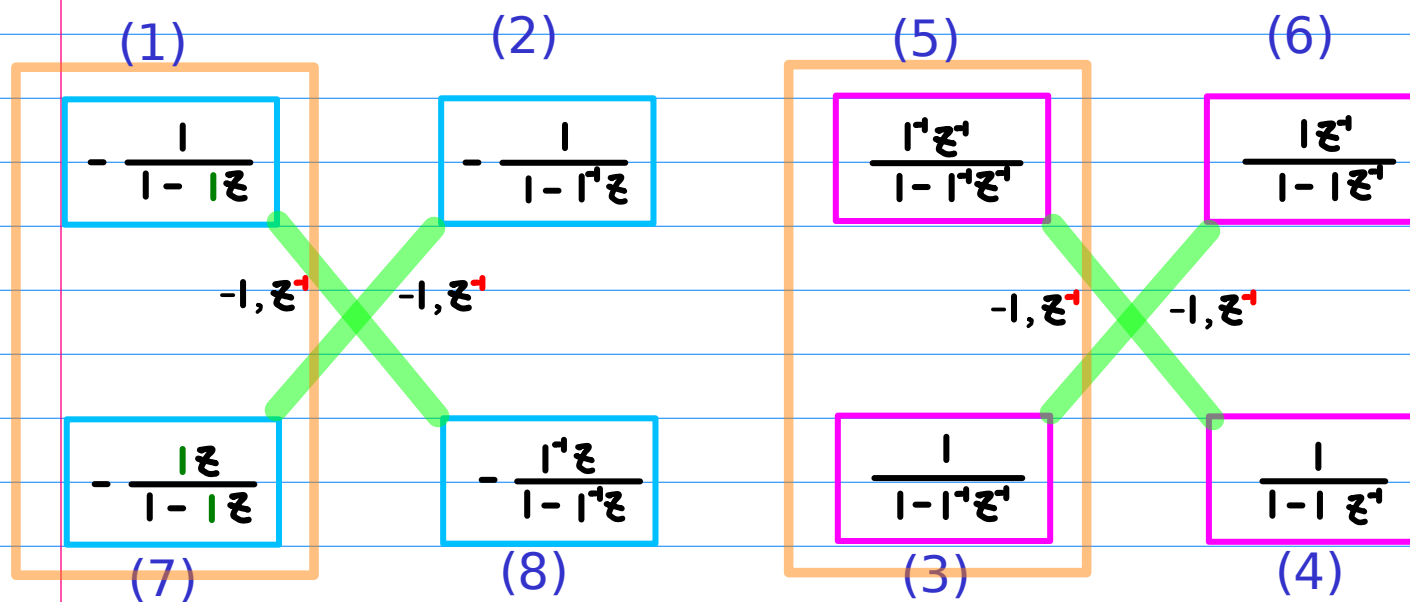
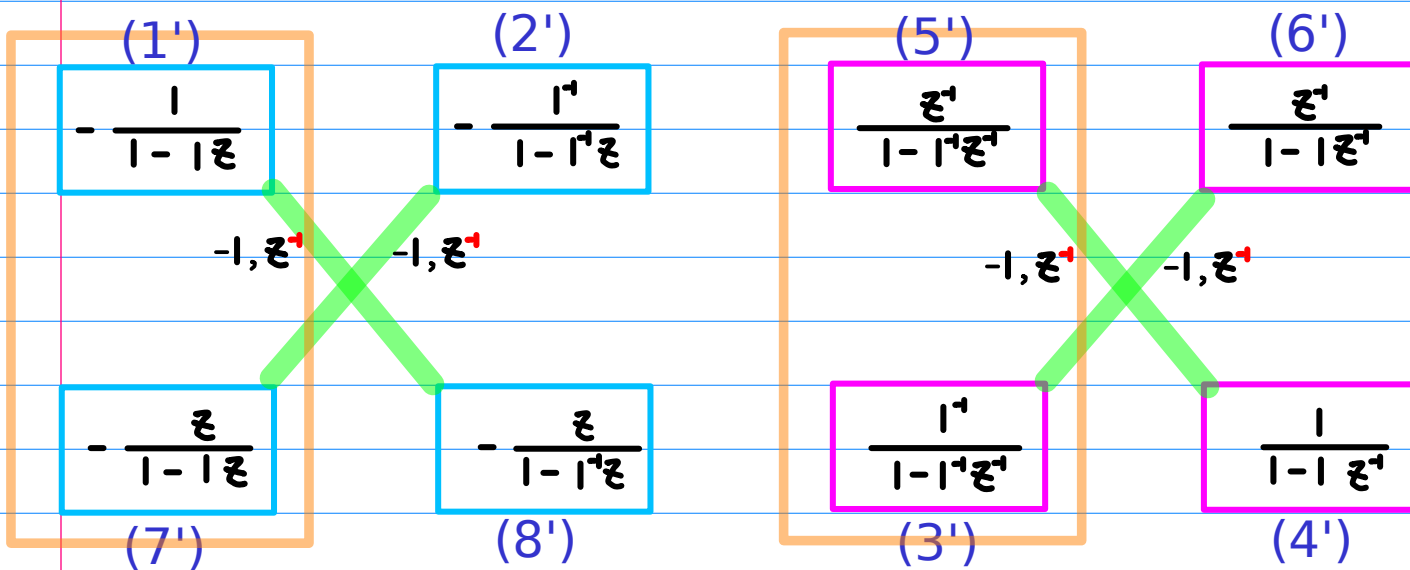
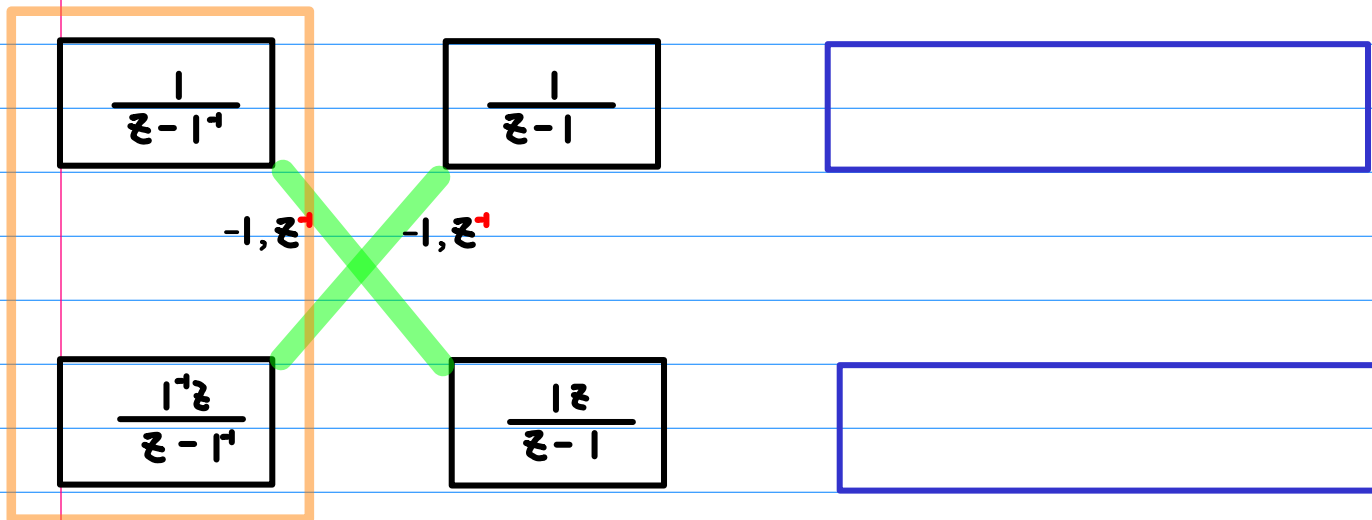

$$P_1 = 1$$

$$P_2 = 1$$

$$\frac{1}{z-1^+}$$

$$\frac{1}{z-1}$$

$$\frac{1}{z-1}$$

$$\frac{1}{z^{-1}-1^+}$$

$$\frac{1}{z^{-1}-1}$$

$$\frac{1^+z}{z-1^+}$$

$$\frac{1z}{z-1}$$

$$\frac{1z}{z-1}$$

$$-\frac{1}{1-1^+z}$$

$$-\frac{1^+}{1-1^+z}$$

$$\frac{z^+}{1-1^+z^+}$$

$$\frac{z^+}{1-1z^+}$$

$$-\frac{1}{1-1z^{-1}}$$

$$-\frac{1^+}{1-1^+z^{-1}}$$

$$\frac{z^+}{1-1^+z^+}$$

$$\frac{z^+}{1-1z^+}$$

$$-\frac{z}{1-1z}$$

$$-\frac{z}{1-1^+z}$$

$$\frac{1^+}{1-1^+z^+}$$

$$\frac{1}{1-1z^+}$$

$$-\frac{1}{1-1z}$$

$$-\frac{1}{1-1^+z}$$

$$\frac{1^+z^+}{1-1^+z^+}$$

$$\frac{1z^+}{1-1z^+}$$

$$-\frac{1}{1-1z^{-1}}$$

$$-\frac{1^+}{1-1^+z^{-1}}$$

$$\frac{1^+z^+}{1-1^+z^+}$$

$$\frac{1z^+}{1-1z^+}$$

$$-\frac{1z}{1-1z}$$

$$-\frac{1^+z}{1-1^+z}$$

$$\frac{1}{1-1^+z^+}$$

$$\frac{1}{1-1z^+}$$

$$P_1 = 0.5$$

$$P_2 = 2$$

$$\frac{1}{z-0.5}$$

$$\frac{1}{z-2}$$

 $-1, z^{-1}$
 $-1, z^{-1}$

$$\frac{0.5z}{z-0.5}$$

$$\frac{2z}{z-2}$$

$$\frac{3}{2} \frac{-1}{(z-0.5)(z-2)}$$

$$-\frac{3}{2} \frac{z^2}{(z-0.5)(z-2)}$$

 $(1')$

$$-\frac{2}{1-2z}$$

 $-1, z^{-1}$
 $(2')$

$$-\frac{0.5}{1-0.5z}$$

 $-1, z^{-1}$

$$-\frac{z}{1-2z}$$

 $(7')$

$$-\frac{z}{1-0.5z}$$

 $(8')$
 $(5')$

$$\frac{z^1}{1-0.5z^1}$$

 $-1, z^{-1}$
 $(6')$

$$\frac{z^1}{1-2z^1}$$

 $-1, z^{-1}$

$$\frac{0.5}{1-0.5z^1}$$

 $(3')$

$$\frac{2}{1-2z^1}$$

 $(4')$
 (1)

$$-\frac{1}{1-2z}$$

 $-1, z^{-1}$
 (2)

$$-\frac{1}{1-0.5z}$$

 $-1, z^{-1}$

$$-\frac{2z}{1-2z}$$

 (7)

$$-\frac{0.5z}{1-0.5z}$$

 (8)
 (5)

$$\frac{0.5z^1}{1-0.5z^1}$$

 $-1, z^{-1}$
 (6)

$$\frac{2z^1}{1-2z^1}$$

 $-1, z^{-1}$

$$\frac{1}{1-0.5z^1}$$

 (3)

$$\frac{1}{1-2z^1}$$

 (4)

$$P_1 = 0.5$$

$$P_2 = 2$$

$$\frac{1}{z-0.5}$$

$$\frac{1}{z-2}$$

$$\frac{3}{2} \frac{-1}{(z-0.5)(z-2)}$$

$$\frac{1}{z^{-1}-0.5}$$

$$\frac{1}{z^{-1}-2}$$

$$\frac{0.5z}{z-0.5}$$

$$\frac{2z}{z-2}$$

$$-\frac{3}{2} \frac{z^2}{(z-0.5)(z-2)}$$

$$-\frac{2}{1-2z}$$

$$-\frac{0.5}{1-0.5z}$$

$$\frac{z^1}{1-0.5z^1}$$

$$\frac{z^1}{1-2z^1}$$

$$-\frac{2}{1-2z^{-1}}$$

$$-\frac{0.5}{1-0.5z^{-1}}$$

$$\frac{z^{-1}}{1-0.5z^{-1}}$$

$$\frac{z^{-1}}{1-2z^{-1}}$$

$$-\frac{z}{1-2z}$$

$$-\frac{z}{1-0.5z}$$

$$\frac{0.5}{1-0.5z^1}$$

$$\frac{2}{1-2z^1}$$

$$-\frac{1}{1-2z}$$

$$-\frac{1}{1-0.5z}$$

$$\frac{0.5z^1}{1-0.5z^1}$$

$$\frac{2z^1}{1-2z^1}$$

$$-\frac{1}{1-2z^{-1}}$$

$$-\frac{1}{1-0.5z^{-1}}$$

$$\frac{0.5z^{-1}}{1-0.5z^{-1}}$$

$$\frac{2z^{-1}}{1-2z^{-1}}$$

$$-\frac{2z}{1-2z}$$

$$-\frac{0.5z}{1-0.5z}$$

$$\frac{1}{1-0.5z^1}$$

$$\frac{1}{1-2z^1}$$

(1) (5)	(2) (6)
(7) (3)	(8) (4)
(1') (5')	(2')(6')
(7') (3')	(8')(4')

Partial fractions and geometric power series

$$\mathcal{P}_1 = 1$$

$$\mathcal{P}_2 = 2$$

(1)
$$\frac{1}{1-z}$$

 $1^n u(n)$

(5)
$$\frac{z}{1-z}$$

 $1^n u(n-1)$

(2)
$$\frac{1}{1-0.5z}$$

 $2^{-n} u(n)$

(6)
$$\frac{2z}{1-2z}$$

 $2^{-n} u(n-1)$

(7)
$$\frac{z}{1-z}$$

 $1^n u(n-1)$

(3)
$$\frac{1}{1-z}$$

 $1^n u(n)$

(8)
$$\frac{0.5z}{1-0.5z}$$

 $2^{-n} u(n-1)$

(4)
$$\frac{1}{1-2z}$$

 $2^{-n} u(n)$

(1')
$$\frac{1}{1-z}$$

 $1^{n+1} u(n)$

(5')
$$\frac{z}{1-z}$$

 $1^{n+1} u(n-1)$

(2')
$$\frac{0.5}{1-0.5z}$$

 $2^{-n-1} u(n)$

(6')
$$\frac{z}{1-2z}$$

 $2^{-n-1} u(n-1)$

(7')
$$\frac{z}{1-z}$$

 $1^{n-1} u(n-1)$

(3')
$$\frac{1}{1-z}$$

 $1^{n-1} u(n)$

(8')
$$\frac{z}{1-0.5z}$$

 $2^{-n-1} u(n-1)$

(4')
$$\frac{2}{1-2z}$$

 $2^{-n-1} u(n)$

(1) (5)
(7) (3)

(2) (6)
(8) (4)

Complementary, Shifted, Symmetric Ranges

(1') (5')
(7') (3')

(2') (6')
(8') (4')

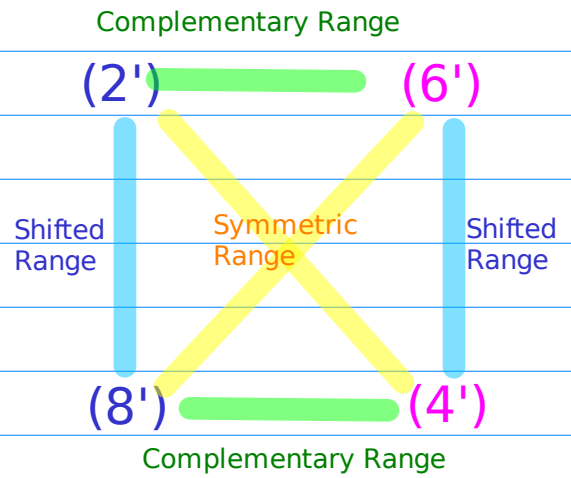
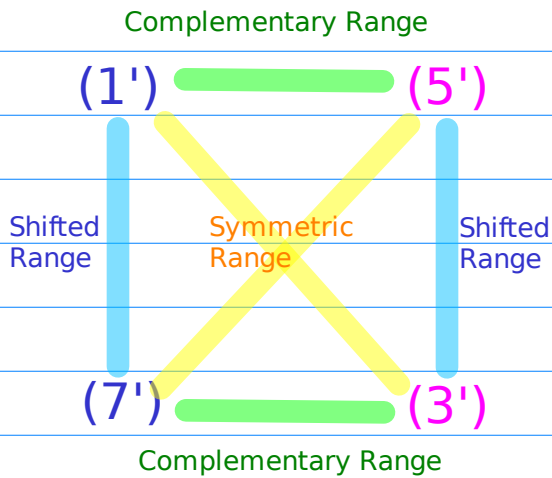
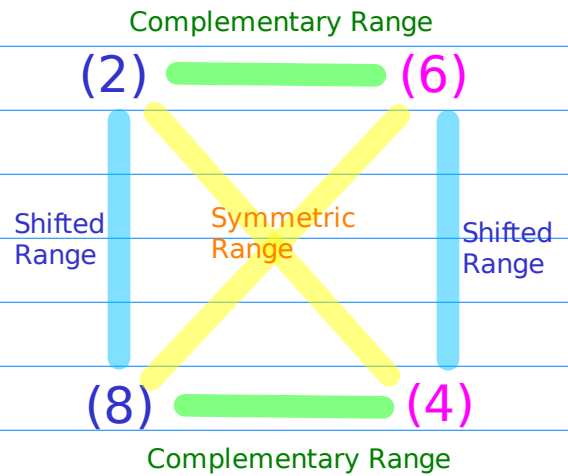
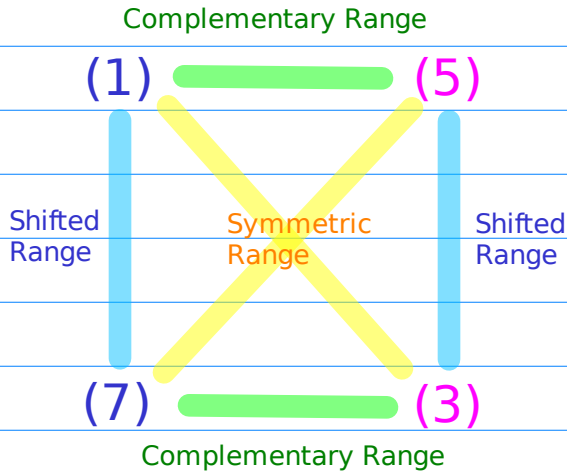

Shifting Geometric Series (1) positive exponent

Positive Exponent

$$a=1$$

$$/z \quad n \leftarrow n+1$$

$$*z \quad n \leftarrow n-1$$

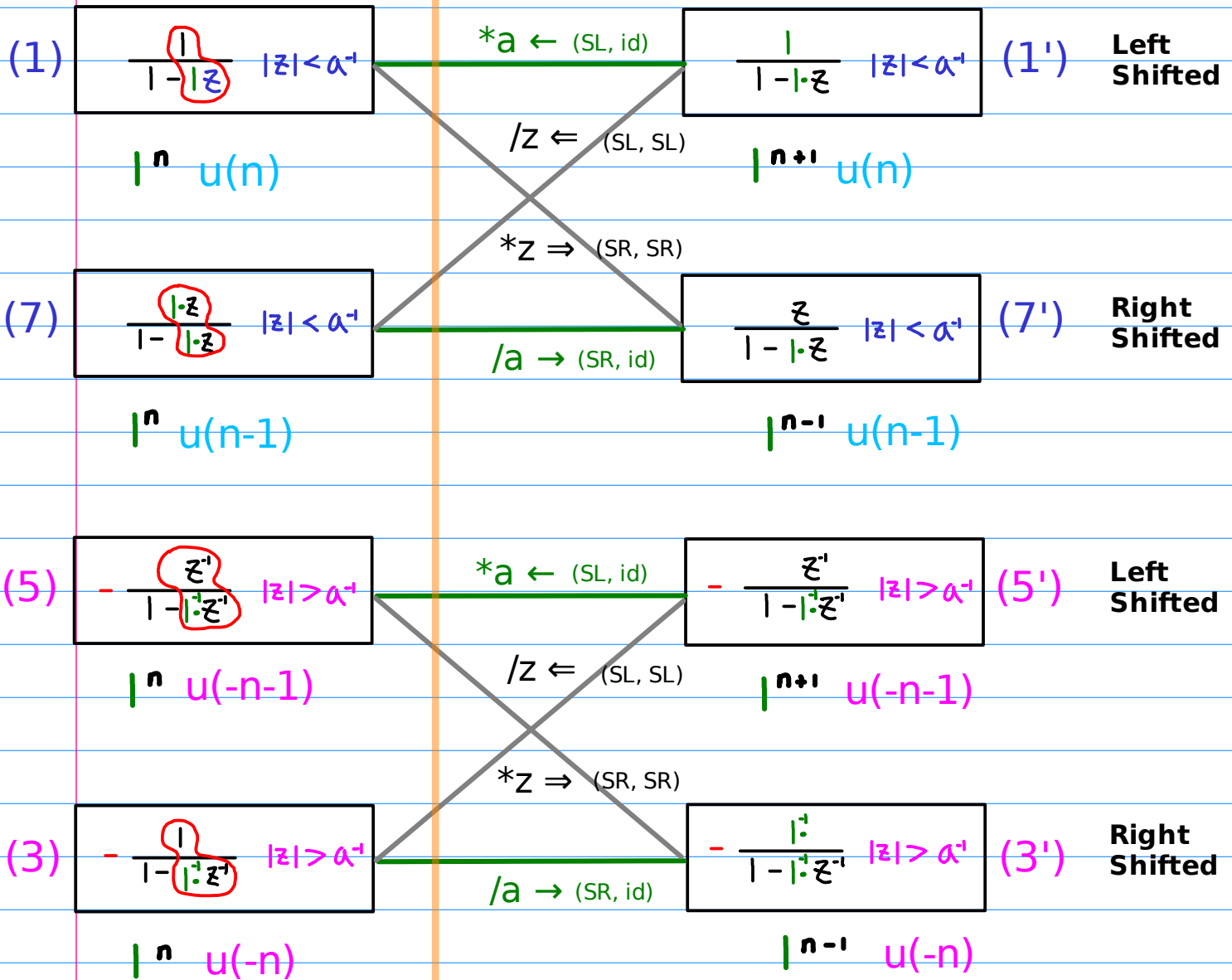

Causal	$u(n)$	(1)	(2)
	$u(n-1)$	(7)	(8)
Anti-Causal	$u(-n-1)$	(5)	(6)
	$u(-n)$	(3)	(4)

butterfly pair ordering

Shifting Geometric Series (2) negative exponent

Negative Exponent $a^{-1} = |^{-1}$ $/z \quad n \leftarrow n+1$ $*z \quad n \leftarrow n-1$

(2) $\frac{1}{1-|^{-1}z} \quad |z| < a$ $\xrightarrow{/a \leftarrow}$ $\frac{|^{-1}}{1-|^{-1}z} \quad |z| < a$ (2') **Left Shifted**
 $|^{-n} u(n)$ $\xrightarrow{/z \leftarrow}$ $|^{-n-1} u(n)$

(8) $\frac{|^{-1}z}{1-|^{-1}z} \quad |z| < a$ $\xrightarrow{*z \Rightarrow}$ $\frac{z}{1-|^{-1}z} \quad |z| < a$ (8') **Right Shifted**
 $|^{-n} u(n-1)$ $\xrightarrow{*a \rightarrow}$ $|^{-n+1} u(n-1)$

(6) $-\frac{|^{-1}z^{-1}}{1-|^{-1}z^{-1}} \quad |z| > a$ $\xrightarrow{/a \leftarrow}$ $-\frac{z^{-1}}{1-|^{-1}z^{-1}} \quad |z| > a$ (6') **Left Shifted**
 $|^{-n} u(-n-1)$ $\xrightarrow{/z \leftarrow}$ $|^{-n-1} u(-n-1)$

(4) $-\frac{1}{1-|^{-1}z^{-1}} \quad |z| > a$ $\xrightarrow{*z \Rightarrow}$ $-\frac{|^{-1}}{1-|^{-1}z^{-1}} \quad |z| > a$ (4') **Right Shifted**
 $|^{-n} u(-n)$ $\xrightarrow{*a \rightarrow}$ $|^{-n+1} u(-n)$

Causal	$u(n)$	(1)	(2)	butterfly pair ordering
	$u(n-1)$	(7)	(8)	
Anti-Causal	$u(-n-1)$	(5)	(6)	
	$u(-n)$	(3)	(4)	

Shifting Geometric Series (2) negative exponent

Negative Exponent $a^{-1} = z^{-1}$ /z $n \leftarrow n+1$ *z $n \leftarrow n-1$

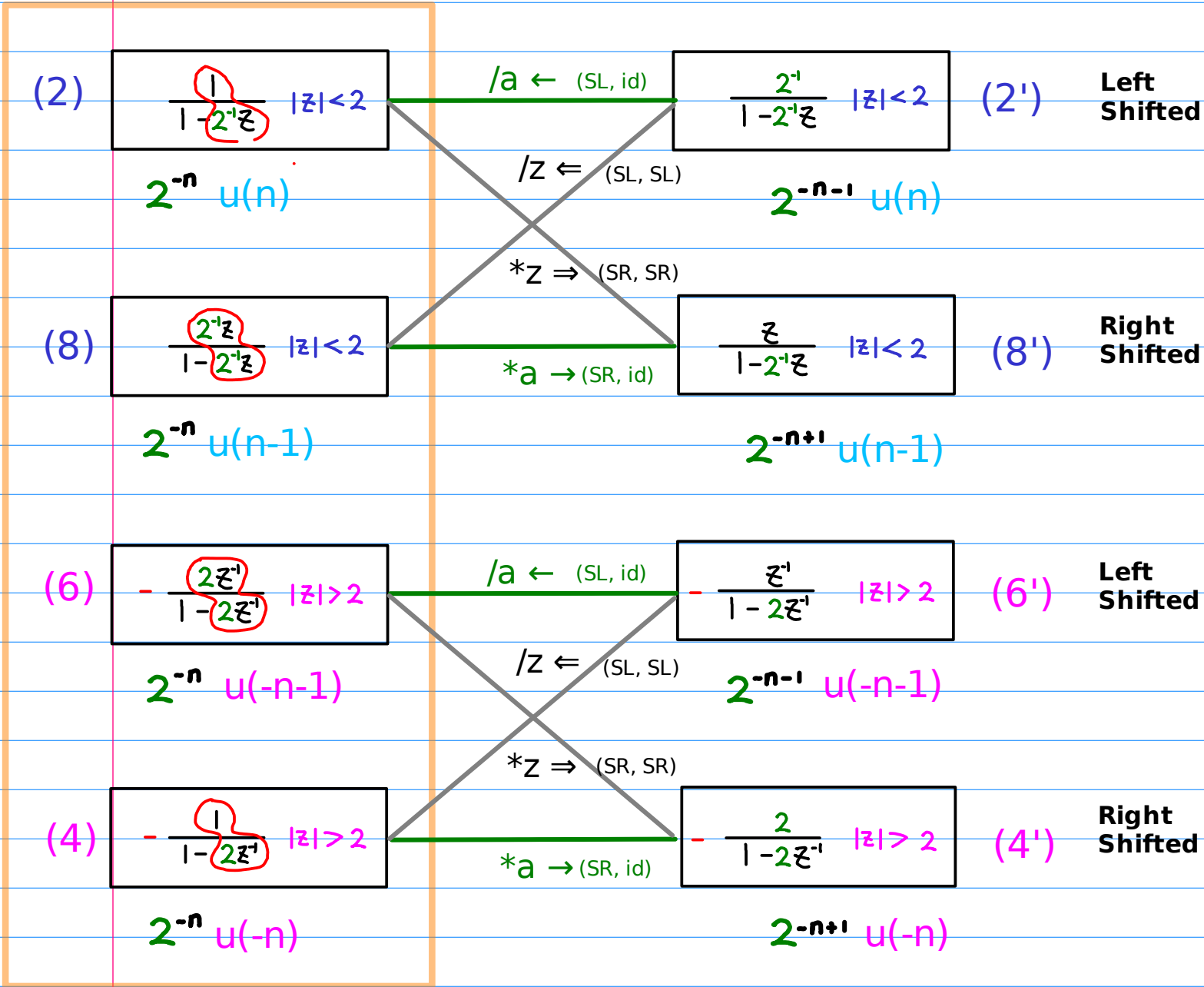

Causal	$u(n)$	(1)	(2)
	$u(n-1)$	(7)	(8)
Anti-Causal	$u(-n-1)$	(5)	(6)
	$u(-n)$	(3)	(4)

butterfly pair ordering

Decoding Geometric Series

Positive Exponent

$$|z, |^{-1}z^{-1} \rightarrow |^n$$

$$2z, 2^{-1}z^{-1} \rightarrow 2^n$$

Negative Exponent

$$|^{-1}z, |z^{-1} \rightarrow |^{-n}$$

$$2^{-1}z, 2z^{-1} \rightarrow 2^{-n}$$

Causal

$$\square z \rightarrow u(n), u(n-1)$$

$$\frac{1}{1-\square z} \rightarrow u(n)$$

$$\frac{\square z}{1-\square z} \rightarrow u(n-1)$$

Anti-causal

$$\square z^{-1} \rightarrow u(-n), u(-n-1)$$

$$\frac{1}{1-\square z^{-1}} \rightarrow u(-n)$$

$$\frac{\square z^{-1}}{1-\square z^{-1}} \rightarrow u(-n-1)$$

$a=1$

(1) (2)
(3) (4)

Unshifted combinations

$\mathcal{P}_1 = 1$

$a^{-1}=2^{-1}$

(5) (6)
(7) (8)

including the origin

$\mathcal{P}_2 = 2$

$a=1$

$a=2$

(1)

$1z$

$f(z) = \frac{1}{1-z}$	$ z < 1$
$1^n u(n)$	$(n \geq 0)$

(2)

$2^{-1}z$

$g(z) = \frac{1}{1-2^{-1}z}$	$ z < 2$
$(\frac{1}{2})^n u(n)$	$(n \geq 0)$

(3)

$1^{-1}z^{-1}$

$\bar{f}_1(z) = \frac{1}{1- ^{-1}z^{-1}}$	$ z > 1$
$1^n u(-n)$	$(n < 0)$

(4)

$2z^{-1}$

$\bar{g}_1(z) = \frac{1}{1-2z^{-1}}$	$ z > 2$
$(\frac{1}{2})^n u(-n)$	$(n < 0)$

(5)

$1^{-1}z^{-1}$

$\bar{f}(z) = \frac{ ^{-1}z^{-1}}{1- ^{-1}z^{-1}}$	$ z > 1$
$1^n u(-n-1)$	$(n < 0)$

(6)

$2z^{-1}$

$\bar{g}(z) = \frac{2z^{-1}}{1-2z^{-1}}$	$ z > 2$
$(\frac{1}{2})^n u(-n-1)$	$(n < 0)$

(7)

$1z$

$f_1(z) = \frac{ z}{1- z}$	$ z < 1$
$1^n u(n-1)$	$(n \geq 1)$

(8)

$2^{-1}z$

$g_1(z) = \frac{2^{-1}z}{1-2^{-1}z}$	$ z < 2$
$(\frac{1}{2})^n u(n-1)$	$(n \geq 1)$

$$a=1$$

$$\begin{matrix} (1') & (2') \\ (3') & (4') \end{matrix}$$

Shifted combinations

$$P_1 = 1$$

$$a^{-1}=2^{-1}$$

$$\begin{matrix} (5') & (6') \\ (7') & (8') \end{matrix}$$

excluding the origin

$$P_2 = 2$$

$$a=1$$

$$a=2$$

(1')

(2')

$$1z$$

$$f_2(z) = \frac{1}{1-z} \quad |z| < 1$$

$$|^{n+1} u(n) \quad (n \geq 0)$$

$$2^{-1}z$$

$$g_2(z) = \frac{2^{-1}}{1-2^{-1}z} \quad |z| < 2$$

$$\left(\frac{1}{2}\right)^{n+1} u(n) \quad (n \geq 0)$$

(3')

(4')

$$1^{-1}z^{-1}$$

$$\bar{f}_3(z) = \frac{1^{-1}}{1-1^{-1}z^{-1}} \quad |z| > 1$$

$$|^{n-1} u(-n) \quad (n < 1)$$

$$2z^{-1}$$

$$\bar{g}_3(z) = \frac{2}{1-2z^{-1}} \quad |z| > 2$$

$$\left(\frac{1}{2}\right)^{n-1} u(-n) \quad (n < 1)$$

(5')

(6')

$$1^{-1}z^{-1}$$

$$\bar{f}_2(z) = \frac{z^{-1}}{1-1^{-1}z^{-1}} \quad |z| > 1$$

$$|^{n+1} u(-n-1) \quad (n < 0)$$

$$2z^{-1}$$

$$\bar{g}_2(z) = \frac{z^{-1}}{1-2z^{-1}} \quad |z| > 2$$

$$\left(\frac{1}{2}\right)^{n+1} u(-n-1) \quad (n < 0)$$

(7')

(8')

$$1z$$

$$f_3(z) = \frac{z}{1-z} \quad |z| < 1$$

$$|^{n-1} u(n-1) \quad (n \geq 1)$$

$$2^{-1}z$$

$$g_3(z) = \frac{z}{1-2^{-1}z} \quad |z| < 2$$

$$\left(\frac{1}{2}\right)^{n-1} u(n-1) \quad (n \geq 1)$$



(1') (2')
(1) (2)

Geometric series for unshifted combinations

$$- \frac{1}{(z-1)(z-2)}$$

(5') (6')
(5) (6)

a=1

a=2

(1')

$f_2(z) = \frac{1}{1-z}$	$ z < 1$
$1^{n+1} u(n)$	$(n \geq 0)$

(2')

$g_2(z) = \frac{2^1}{1-2^1 z}$	$ z < 2$
$(\frac{1}{2})^{n+1} u(n)$	$(n \geq 0)$

(1)

$f(z) = \frac{1}{1-z}$	$ z < 1$
$1^n u(n)$	$(n \geq 0)$

(2)

$g(z) = \frac{1}{1-2z}$	$ z < 2$
$(\frac{1}{2})^n u(n)$	$(n \geq 0)$

(5')

$\bar{f}_2(z) = \frac{z^1}{1-z^1}$	$ z > 1$
$1^{n+1} u(-n-1)$	$(n < 0)$

(6')

$\bar{g}_2(z) = \frac{z^1}{1-2z^1}$	$ z > 2$
$(\frac{1}{2})^{n+1} u(-n-1)$	$(n < 0)$

(5)

$\bar{f}(z) = \frac{1^1 z^1}{1-1^1 z^1}$	$ z > 1$
$1^n u(-n-1)$	$(n < 0)$

(6)

$\bar{g}(z) = \frac{2z^1}{1-2z^1}$	$ z > 2$
$(\frac{1}{2})^n u(-n-1)$	$(n < 0)$

(7') (8')
(7) (8)

(3') (4')
(3) (4)

Geometric series for unshifted combinations

$$-\frac{z^2}{(z-1)(z-2)}$$

a=1

(7')

$f_3(z) = \frac{z}{1-z}$	$ z < 1$
$ ^{n-1} u(n-1)$	$(n \geq 1)$

(7)

$f_1(z) = \frac{ z}{1- z}$	$ z < 1$
$ ^n u(n-1)$	$(n \geq 1)$

a=2

(8')

$g_3(z) = \frac{z}{1-2z}$	$ z < 2$
$(\frac{1}{2})^{n-1} u(n-1)$	$(n \geq 1)$

(8)

$g_1(z) = \frac{2z}{1-2z}$	$ z < 2$
$(\frac{1}{2})^n u(n-1)$	$(n \geq 1)$

(3')

$\bar{f}_3(z) = \frac{ z}{1- z^{-1}}$	$ z > 1$
$ ^{n-1} u(-n)$	$(n < 1)$

(3)

$\bar{f}_1(z) = \frac{1}{1- z^{-1}}$	$ z > 1$
$ ^n u(-n)$	$(n < 1)$

(4')

$\bar{g}_3(z) = \frac{2}{1-2z^{-1}}$	$ z > 2$
$(\frac{1}{2})^{n-1} u(-n)$	$(n < 1)$

(4)

$\bar{g}_1(z) = \frac{1}{1-2z^{-1}}$	$ z > 2$
$(\frac{1}{2})^n u(-n)$	$(n < 1)$

$$\frac{1}{(z-1)(z-2)} = \left(\frac{1}{z-1} - \frac{1}{z-2} \right)$$

Case A $|z| < 0.5$

$$-\frac{1}{(z-1)(z-2)}$$

$$-\frac{1}{(z-1)(z-2)} = \left(\frac{1}{z-1} - \frac{1}{z-2} \right)$$

Simple Pole Form

$$\frac{1}{z-1}$$

$$\frac{1}{z-2}$$

Geometric Power Series Forms

$$-\frac{1}{1-z}$$

$$-\frac{0.5}{1-0.5z}$$

$|z| < 1$

$|z| < 1$

$|z| < 2$



=

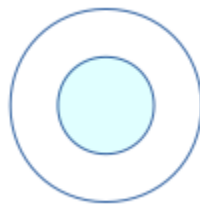

\cap

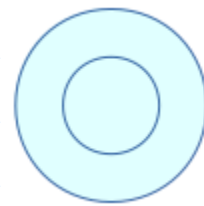

$$-1^{n+1} u(n)$$

$$-\left(\frac{1}{2}\right)^{n+1} u(n)$$

$|z| < 1$

$$f(z) = -\frac{1}{1-z} + \frac{0.5}{1-0.5z}$$

$$-1^{n+1} u(n) + \left(\frac{1}{2}\right)^{n+1} u(n)$$

(1')

$f_2(z) = \frac{1}{1-z}$	$ z < 1$
$1^{n+1} u(n)$	$(n \geq 0)$

(2')

$g_2(z) = \frac{2^n}{1-2^n z}$	$ z < 2$
$\left(\frac{1}{2}\right)^{n+1} u(n)$	$(n \geq 0)$

(1)

$f(z) = \frac{1}{1-z}$	$ z < 1$
$1^n u(n)$	$(n \geq 0)$

$g(z) = \frac{1}{1-2^n z}$	$ z < 2$
$\left(\frac{1}{2}\right)^n u(n)$	$(n \geq 0)$

Case B $0.5 < |z| < 2$

$$-\frac{1}{(z-1)(z-2)}$$

$$-\frac{1}{(z-1)(z-2)} = \left(\frac{1}{z-1} - \frac{1}{z-2} \right)$$

Simple Pole Form

$$\frac{1}{z-1}$$

$$\frac{1}{z-2}$$

Geometric Power Series Forms

$$\frac{z^{-1}}{1-z^{-1}}$$

$$-\frac{0.5}{1-0.5z}$$

$1 < |z| < 2$

$|z| < 1$

$|z| < 2$



=

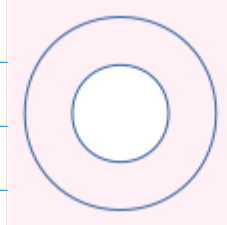

∩

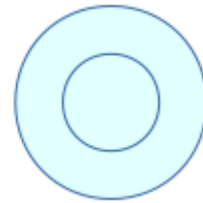

$$|^{n+1} u(-n-1)$$

$$-\left(\frac{1}{2}\right)^{n+1} u(n)$$

$$1 < |z| < 2 \quad f(z) = \frac{z^{-1}}{1-z^{-1}} + \frac{0.5}{1-0.5z} \quad |^{n+1} u(-n-1) + \left(\frac{1}{2}\right)^{n+1} u(n)$$

(5')

$\bar{f}_2(z) = \frac{z^{-1}}{1-z^{-1}} \quad z > 1$	
$ ^{n+1} u(-n-1) \quad (n < 0)$	

(2')

$g_2(z) = \frac{2^{-1}}{1-2^{-1}z} \quad z < 2$	
$\left(\frac{1}{2}\right)^{n+1} u(n) \quad (n \geq 0)$	

(5)

$\bar{f}(z) = \frac{1^{-1}z^{-1}}{1-1^{-1}z^{-1}} \quad z > 1$	
$1^n u(-n-1) \quad (n < 0)$	

(2)

$g(z) = \frac{1}{1-2^{-1}z} \quad z < 2$	
$\left(\frac{1}{2}\right)^n u(n) \quad (n \geq 0)$	

Case C $2 < |z|$

$$-\frac{1}{(z-1)(z-2)}$$

$$-\frac{1}{(z-1)(z-2)} = \left(\frac{1}{z-1} - \frac{1}{z-2} \right)$$

Simple Pole Form

Geometric Power Series Forms

$$\frac{1}{z-1}$$

$$\frac{z^{-1}}{1-z^{-1}}$$

$$1 < |z|$$

$$\frac{1}{z-2}$$

$$\frac{z^{-1}}{1-2z^{-1}}$$

$$2 < |z|$$

$$2 < |z|$$

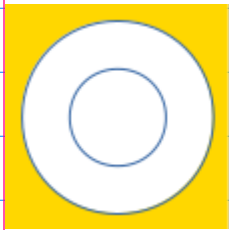

=

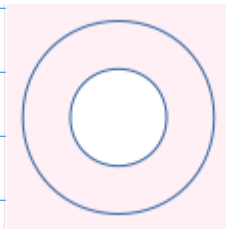

∩

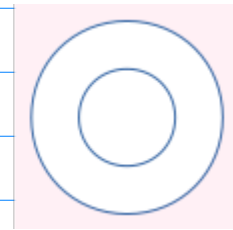

$$|z|^{n+1} u(-n-1)$$

$$\left(\frac{1}{2}\right)^{n+1} u(-n-1)$$

$$2 < |z|$$

$$f(z) = \frac{z^{-1}}{1-z^{-1}} - \frac{z^{-1}}{1-2z^{-1}}$$

$$|z|^{n+1} u(-n-1) - \left(\frac{1}{2}\right)^{n+1} u(-n-1)$$

(5')

$$\bar{f}_2(z) = \frac{z^{-1}}{1-z^{-1}} \quad |z| > 1$$

$$|z|^{n+1} u(-n-1) \quad (n < 0)$$

(6')

$$\bar{g}_2(z) = \frac{z^{-1}}{1-2z^{-1}} \quad |z| > 2$$

$$\left(\frac{1}{2}\right)^{n+1} u(-n-1) \quad (n < 0)$$

(5)

$$\bar{f}(z) = \frac{|z|^{-1} z^{-1}}{1-|z|^{-1} z^{-1}} \quad |z| > 1$$

$$|z|^n u(-n-1) \quad (n < 0)$$

(6)

$$\bar{g}(z) = \frac{2z^{-1}}{1-2z^{-1}} \quad |z| > 2$$

$$\left(\frac{1}{2}\right)^n u(-n-1) \quad (n < 0)$$

Laurent Series and z Transform

$$-\frac{1}{(z-1)(z-2)}$$

$$-\frac{1}{(z-1)(z-2)} = \left(\frac{1}{z-1} - \frac{1}{z-2} \right)$$

$$|z| < 1 \quad f(z) = -\frac{1}{1-z} + \frac{0.5}{1-0.5z}$$

Laurent Series

$$-1^{n+1} u(n) + \left(\frac{1}{2}\right)^{n+1} u(n)$$

z Transform

$$-1^{-n+1} u(-n) + \left(\frac{1}{2}\right)^{-n+1} u(-n) \\ -\left(\frac{1}{1}\right)^{n-1} u(-n) + 2^{n-1} u(-n)$$

$$1 < |z| < 2 \quad f(z) = \frac{z^{-1}}{1-z^{-1}} + \frac{0.5}{1-0.5z}$$

Laurent Series

$$1^{n+1} u(-n-1) + \left(\frac{1}{2}\right)^{n+1} u(n)$$

z Transform

$$1^{-n+1} u(n-1) + \left(\frac{1}{2}\right)^{-n+1} u(-n) \\ \left(\frac{1}{1}\right)^{n-1} u(n-1) + 2^{n-1} u(-n)$$

$$2 < |z| \quad f(z) = \frac{z^{-1}}{1-z^{-1}} - \frac{z^{-1}}{1-2z^{-1}}$$

Laurent Series

$$1^{n+1} u(-n-1) - \left(\frac{1}{2}\right)^{n+1} u(-n-1)$$

z Transform

$$1^{-n+1} u(n-1) - \left(\frac{1}{2}\right)^{-n+1} u(n-1) \\ \left(\frac{1}{1}\right)^{n-1} u(n-1) + 2^{n-1} u(n-1)$$

$$-\frac{z^2}{(z-1)(z-2)} = \left(\frac{z}{z-1} - \frac{2z}{z-2} \right)$$

Case A $|z| < 0.5$

$$-\frac{z^2}{(z-1)(z-2)}$$

$$-\frac{z^2}{(z-1)(z-2)} = \left(\frac{z}{z-1} - \frac{2z}{z-2} \right)$$

Simple Pole Form

$$\frac{z}{z-1}$$

$$\frac{2z}{z-2}$$

Geometric Power Series Forms

$$-\frac{z}{1-z}$$

$$-\frac{z}{1-0.5z}$$

$|z| < 1$

$|z| < 1$

$|z| < 2$



=

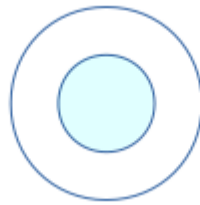

∩

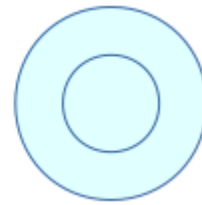

$-1^{n-1} u(n)$

$-\left(\frac{1}{2}\right)^{n-1} u(n)$

$|z| < 1$

$f(z) = -\frac{z}{1-2z} + \frac{z}{1-0.5z}$

$-1^{n-1} u(n) + \left(\frac{1}{2}\right)^{n-1} u(n)$

(7')

$$f_3(z) = \frac{z}{1-z} \quad |z| < 1$$

$$1^{n-1} u(n-1) \quad (n \geq 1)$$

(8')

$$g_3(z) = \frac{z}{1-2z} \quad |z| < 2$$

$$\left(\frac{1}{2}\right)^{n-1} u(n-1) \quad (n \geq 1)$$

(7)

$$f_1(z) = \frac{|z|}{1-|z|} \quad |z| < 1$$

$$1^n u(n-1) \quad (n \geq 1)$$

(8)

$$g_1(z) = \frac{2^n z}{1-2^n z} \quad |z| < 2$$

$$\left(\frac{1}{2}\right)^n u(n-1) \quad (n \geq 1)$$

Case B $0.5 < |z| < 2$

$$-\frac{z^2}{(z-1)(z-2)}$$

$$-\frac{z^2}{(z-1)(z-2)} = \left(\frac{z}{z-1} - \frac{2z}{z-2} \right)$$

Simple Pole Form

$$\frac{z}{z-1}$$

$$\frac{2z}{z-2}$$

Geometric Power Series Forms

$$\frac{1}{1-z^{-1}}$$

$$-\frac{z}{1-0.5z}$$

$1 < |z| < 2$

$1 < |z|$

$|z| < 2$



=

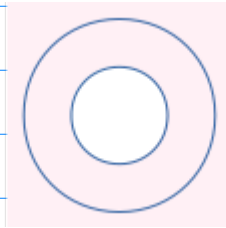

∩

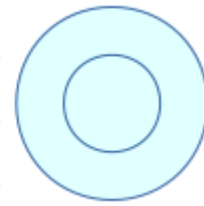

$$|^{n-1} u(-n-1)$$

$$-\left(\frac{1}{2}\right)^{n-1} u(n)$$

$$1 < |z| < 2 \quad f(z) = \frac{1}{1-z^{-1}} + \frac{z}{1-0.5z} \quad |^{n-1} u(-n-1) + \left(\frac{1}{2}\right)^{n-1} u(n)$$

(3')

$\bar{f}_3(z) = \frac{1^{ n }}{1-1^{ n }z^{- n }}$	$ z > 1^{ n }$
$ ^{n-1} u(-n)$	$(n < 1)$

(8')

$g_3(z) = \frac{z}{1-2^{ n }z}$	$ z < 2$
$\left(\frac{1}{2}\right)^{n-1} u(n-1)$	$(n \geq 1)$

(3)

$\bar{f}_1(z) = \frac{1}{1-1^{ n }z^{- n }}$	$ z > 1^{ n }$
$ ^n u(-n)$	$(n < 1)$

(8)

$g_1(z) = \frac{2^{ n }z}{1-2^{ n }z}$	$ z < 2$
$\left(\frac{1}{2}\right)^n u(n-1)$	$(n \geq 1)$

Case C $2 < |z|$

$$-\frac{z^2}{(z-1)(z-2)}$$

$$-\frac{z^2}{(z-1)(z-2)} = \left(\frac{z}{z-1} - \frac{2z}{z-2} \right)$$

Simple Pole Form

$$\frac{z}{z-1}$$

$$\frac{2z}{z-2}$$

Geometric Power Series Forms

$$\frac{1}{1-z^{-1}}$$

$$\frac{2}{1-2z^{-1}}$$

$2 < |z|$

$1 < |z|$

$2 < |z|$

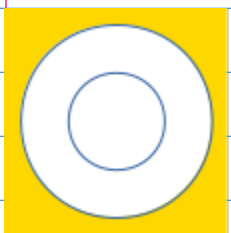

=

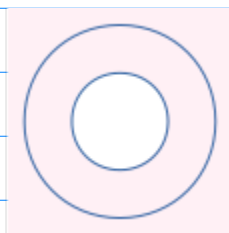

∩

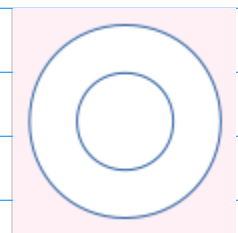

$$1^{n-1} u(-n-1)$$

$$\left(\frac{1}{2}\right)^{n-1} u(-n-1)$$

$2 < |z|$

$$f(z) = \frac{1}{1-z^{-1}} - \frac{2}{1-2z^{-1}}$$

$$1^{n-1} u(-n-1) - \left(\frac{1}{2}\right)^{n-1} u(-n-1)$$

(3')

$$\bar{f}_3(z) = \frac{1^n}{1-1^n z^{-1}} \quad |z| > 1$$

$$1^{n-1} u(-n) \quad (n < 1)$$

(4')

$$\bar{g}_3(z) = \frac{2}{1-2z^{-1}} \quad |z| > 2$$

$$\left(\frac{1}{2}\right)^{n-1} u(-n) \quad (n < 1)$$

(3)

$$\bar{f}_1(z) = \frac{1}{1-1^n z^{-1}} \quad |z| > 1$$

$$1^n u(-n) \quad (n < 1)$$

(4)

$$\bar{g}_1(z) = \frac{1}{1-2z^{-1}} \quad |z| > 2$$

$$\left(\frac{1}{2}\right)^n u(-n) \quad (n < 1)$$

Laurent Series and z Transform

$$-\frac{z^2}{(z-1)(z-2)}$$

$$-\frac{z^2}{(z-1)(z-2)} = \left(\frac{z}{z-1} - \frac{2z}{z-2} \right)$$

$$|z| < 1 \quad f(z) = -\frac{z}{1-2z} + \frac{z}{1-0.5z}$$

Laurent Series

$$-1^{n-1} u(n) + \left(\frac{1}{2}\right)^{n-1} u(n)$$

z Transform

$$-1^{-n-1} u(-n) + \left(\frac{1}{2}\right)^{-n-1} u(-n) \\ -\left(\frac{1}{1}\right)^{n+1} u(-n) + 2^{n+1} u(-n)$$

$$1 < |z| < 2 \quad f(z) = \frac{1}{1-z^{-1}} + \frac{z}{1-0.5z}$$

Laurent Series

$$1^{n-1} u(-n-1) + \left(\frac{1}{2}\right)^{n-1} u(n)$$

z Transform

$$1^{-n-1} u(n-1) + \left(\frac{1}{2}\right)^{-n-1} u(-n) \\ \left(\frac{1}{1}\right)^{n+1} u(n-1) + 2^{n+1} u(-n)$$

$$2 < |z| \quad f(z) = \frac{1}{1-z^{-1}} - \frac{2}{1-2z^{-1}}$$

Laurent Series

$$1^{n-1} u(-n-1) - \left(\frac{1}{2}\right)^{n-1} u(-n-1)$$

z Transform

$$1^{-n-1} u(n-1) - \left(\frac{1}{2}\right)^{-n-1} u(n-1) \\ \left(\frac{1}{1}\right)^{n+1} u(n-1) + 2^{n+1} u(n-1)$$

$$f(z) = g(z^{-1})$$

$$g(z) = f(z^{-1})$$

$$\{1, 2\} \rightarrow \{1, 0.5\}$$

$$\frac{-1}{(z-1)(z-2)} \xleftrightarrow{z^{-1}} \frac{-0.5z^2}{(z-1)(z-0.5)}$$

$$\frac{-1}{(z-1)(z-2)} = \left(\frac{1}{z-1} - \frac{1}{z-2} \right)$$

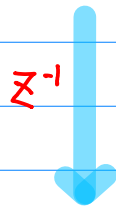

$$\begin{aligned} \frac{-1}{(z^{-1}-1)(z^{-1}-2)} &= \left(\frac{1}{z^{-1}-1} - \frac{1}{z^{-1}-2} \right) \\ &= \left(\frac{z}{1-z} - \frac{z}{1-2z} \right) \\ &= \left(\frac{-z}{z-1} + \frac{0.5z}{z-0.5} \right) \\ &= z \left(\frac{-1}{z-1} + \frac{0.5}{z-0.5} \right) \\ &= z \left(\frac{-0.5z}{(z-1)(z-0.5)} \right) \\ &= \frac{-0.5z^2}{(z-1)(z-0.5)} \end{aligned}$$

$$\frac{-0.5z^2}{(z-1)(z-0.5)} = \left(-\frac{z}{(z-1)} + \frac{0.5z}{(z-0.5)} \right)$$







